

EN

08.2019



Elastomer Jaw Couplings

RINGFEDER® TNS SX

Installation and Operation Manual



Contents

Chapter	Page
1 Safety Instructions	2
2 Technical Description	3
2.1 Intended Application	3
3 Coupling Marking.....	4
3.1 Marking of Buffer Rings	4
4 Storage	4
5 Construction	5
6 Technical Data.....	6
7 Installation	8
7.1 To be observed prior to installation.....	8
7.2 Finish bores	9
7.3 Coupling installation	10
8 Coupling Alignment	11
8.1 Angular Misalignment.....	12
8.2 Radial Misalignment	13
8.3 Axial Misalignment.....	13
9 Operation.....	14
10 Maintenance	17
10.1 Wear Inspection on the Buffer Ring.....	17
10.2 Wear Inspection - Equipment at standstill	18
10.3 Replacement of buffer ring	19
11 Disposal	19

1 Safety Instructions

This installation and operation manual is an essential component of the coupling delivery. Always keep this manual in a readily accessible place near the coupling. Take care that all persons being charged with the installation, operation, maintenance and repair of the coupling have read and understood this manual and that all instructions contained therein are carefully observed in order to:

- avoid danger to life and limb of the user or third persons,
- ensure the operational safety of the coupling,
- preclude operation failures and environmental damages due to wrong handling and misuse.

The relevant instructions and regulations regarding safety at work and environmental protection have to be observed while transporting, mounting and dismounting the coupling.

The coupling shall be operated, mounted, maintained and repaired by authorized, trained and instructed personnel only.

In the interest of further development, we reserve the right to carry out modifications serving the technical progress.

We do not assume any liability or warranty for any damages resulting from the use of accessories and parts that are not originally manufactured by RINGFEDER POWER TRANSMISSION.

2 Technical Description

The RINGFEDER® TNS SX coupling is a torsionally flexible, puncture proof claw coupling which is particularly suited for use with hydrodynamic high-speed couplings. It compensates for angular, radial and axial shaft misalignments within defined limits. The coupling transmits torque through elastic buffers loaded in shear. These buffers come in Perbunan (Pb), Pb82 as a standard, or polyurethane (Vk), and are connected to each other to form an elastic buffer ring.

This buffer ring dampens shocks and torsional vibrations and is resistant to oil.

Buffer rings made of Perbunan are electrically conductive.

The coupling is suitable for use in every direction of rotation and installation position.

2.1 Intended Application

- The coupling must only be operated in normal industrial atmospheres. Since aggressive media may attack the coupling components, screws and elastic buffer rings, they represent a risk for the operational safety of the coupling. Consult RINGFEDER POWER TRANSMISSION in such cases.
- In order to ensure trouble-free and reliable operation, the coupling has to be sized according to the design specifications, e.g. according to DIN 740, part 2, (or acc. to Paper & Tech Paper “Elastomer Jaw Couplings“), with a service factor appropriate for the service conditions.
- Except for the production of a finish bore with keyway, no further modifications are allowed to be carried out on the coupling!
- The coupling shall only be used and operated within the frame of the conditions as defined in the performance or delivery contract.
- Any change in the operation conditions or service parameters requires the verification of the coupling design.

3 Coupling Marking

3.1 Marking of Buffer Rings

The buffer rings are marked on the face of one buffer element as follows:

- Coupling size and material abbreviation (Vk for Polyurethane or Pb for Perbunan)
- Year of construction

- Pb72 = buffer ring of Perbunan, 72 Shore(A) / black
- Pb82 = buffer ring of Perbunan, 82 Shore(A) / black
- VkB = buffer ring of Polyurethane, 83 Shore(A) / blue
- VkR = buffer ring of Polyurethane, 93 Shore(A) / red
- Vk60D = buffer ring of Polyurethane, 60 Shore(D) white/beige

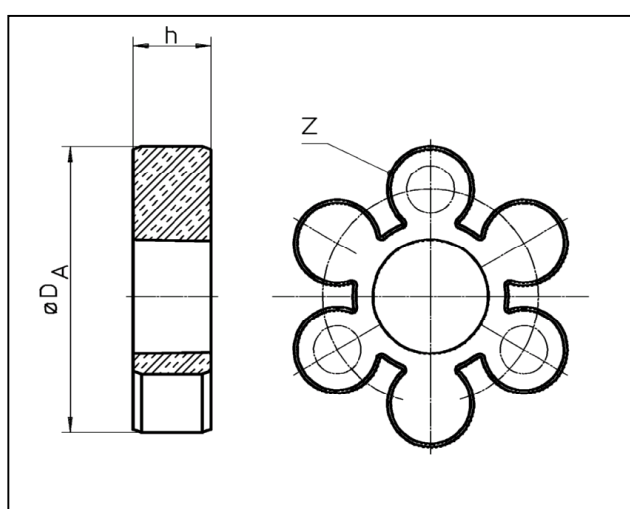

Size	D_A [mm]	h [mm]	z
50	48	12	4
70	70	18	6
85	82	18	6
100	100	20	6
125	121	25	6
145	139	30	6
170	166	30	8
200	194	35	8
230	222	35	10
260	253	45	10
300	294	50	10
360	350	55	12
400	393	55	14

4 Storage

On receipt of the goods, immediately check that all parts are on hand and are as ordered. Eventual shipping damages and/or missing parts have to be reported in writing.

The coupling parts can be stored in the delivered state in a dry place under roof at normal ambient temperatures for a time period of 6 months. Storage for a longer period requires the application of a long-term preservation. (Please consult RINGFEDER POWER TRANSMISSION in this respect.) The buffer rings must not be exposed to ozonic media, direct sun light or intensive light sources with UV light. The air humidity should not exceed 65 %. If the parts are properly stored, the quality characteristics of the elastic buffer rings remains almost unchanged for up to three years.

5 Construction

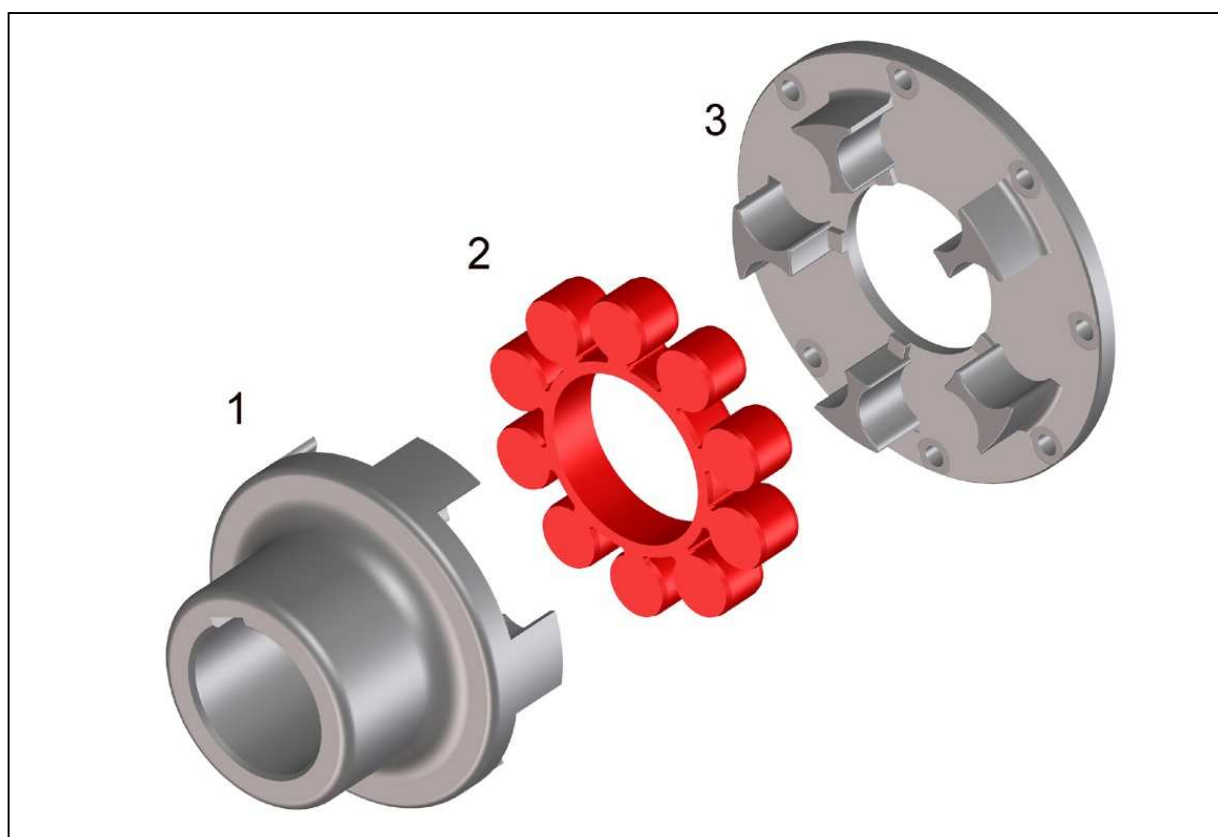

Fig. 1

- 1 Coupling hub, part 200, long hub L, part 210
- 2 Elastic buffer ring, part 020
- 3 Coupling flange, part 230, made of **aluminium** as a standard

6 Technical Data

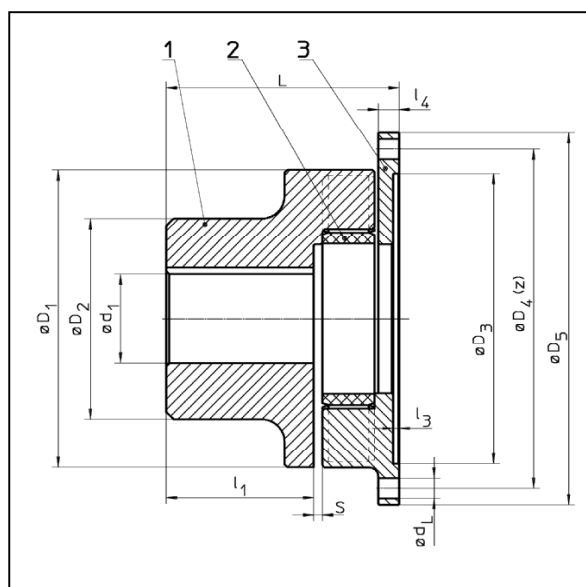

Fig. 2 RINGFEDER® TNS SX

Table 1 Technical Data:

Size SX	n_{max} [min ⁻¹]	T_{Knom} Pb72 [Nm]	T_{Kmax} Pb72 [Nm]	T_{Knom} Pb82 [Nm]	T_{Kmax} Pb82 [Nm]	T_{Knom} VkR [Nm]	T_{Kmax} VkR [Nm]	T_{Knom} VkB [Nm]	T_{Kmax} VkB [Nm]	m unbored [kg]
100	7250	40	120	70	210	130	390	76	228	2,6
125	6000	70	210	128	385	250	750	140	420	4,5
145	5250	120	360	220	660	400	1200	240	720	6,4
170	4500	180	540	340	1020	630	1900	370	1110	10,4
200	3750	330	990	590	1770	1100	3300	640	1920	17,5
230	3250	500	1500	900	2700	1700	5150	980	2940	24,4
260	3000	800	2400	1400	4200	2650	7950	1530	4590	35,8
300	2500	1180	3540	2090	6270	3900	11700	2280	6840	53,2
360-650	2150	1940	5820	3450	10350	6500	19500	3760	11280	84,4
360-750										88,3
400	1900	2670	8010	4750	14250	8900	26700	5180	15540	94,9
400 L										101,2
400-866										100,7
400 L-866										107,0
400-1000										110,0
400 L-1000										116,3
400-1150										124,3
400 L-1150										130,6

- Pb72 = buffer ring of Perbunan - 72 Shore(A) / black
- Pb82 = buffer ring of Perbunan - 82 Shore(A) / black
- VkR = buffer ring of Polyurethane / red
- Vk60D = buffer ring of Polyurethane / white-beige
- VkB = buffer ring of Polyurethane / blue

Size SX	d ₁ max [mm]	D ₁ [mm]	D ₂ [mm]	D ₃ H7 [mm]	D ₄ [mm]	D ₅ [mm]	z x d _L	L [mm]	l ₁ [mm]	l ₃ [mm]	l ₄ [mm]	S [mm]
100	42	105	65	100	128	145	6 x 9	84,5	49,5	2	10	3,0
125	55	126	85	130	148	170	6 x 9	97,0	56,5	2	10	3,5
145	65	145	95	150	172	194	6 x 9	109,0	61,0	4	12	4,0
170	85	170	120	170	195	220	6 x 13,5	126,5	75,0	4	14	5,0
200	95	200	135	195	228	250	8 x 13,5	156,5	99,0	4	14	6,0
230	105	230	150	220	265	290	8 x 13,5	171,0	110,0	4	15	7,0
260	125	260	180	265	310	335	12 x 13,5	187,5	112,5	4	18	7,0
300	140	300	200	315	360	385	16 x 13,5	218,5	131,5	4	24	8,0
360-650	150	360	210	360	420	455	16 x 17,5	271,5	172,0	5	28	7,5
360-750				420	480	514	20 x 17,5	273,5		5	30	
400	160	400	225	420	480	514	20 x 17,5	265,0	163,5	5	30	7,5
400 L				285,0	183,5							
400-866				265,0	163,5	6	30					
400 L-866				285,0	183,5							
400-1000				268,0	163,5	6	30					
400 L-1000				288,0	183,5							
400-1150				262,0	163,5	-6	27					
400 L-1150				282,0	183,5							

The torques T_{Knom} and T_{Kmax} are valid for:

- Ambient temperatures of -30°C up to $+30^{\circ}\text{C}$ for Polyurethane (Vk),
- Ambient temperatures of -30°C up to $+60^{\circ}\text{C}$ for Perbunan (Pb)
- Operation within the range of the specified alignment values.

For determining the size of the coupling according to DIN 740, part 2, (or to Paper & Tech Paper "Elastomer Jaw Couplings") various factors have to be taken into account:

- the temperature factor S_v in case of higher temperatures,
- the start-up factor S_z depending on the frequency of starts,
- the shock factor S_A, S_L depending on the service conditions.

For circumferential speeds above 22 m/s, referred to the nominal size of the coupling, we recommend balancing the steel parts of the coupling.

7 Installation

7.1 To be observed prior to installation



- **Danger of injuries!**
 - **Disconnect the drive before carrying out any work on the coupling!**
 - **Secure the drive against unintentional re-start and rotation!**
 - **Incorrectly tightened bolts can cause serious personal injuries and property damages!**
 - **Assemble the coupling outside of the danger zone. Take care that suitable transportation means are at disposal and that the transportation ways are free of obstacles. Do not use tools containing iron when mounting the parts in explosive areas.**
 - **In compliance with accident prevention regulations, you are obliged to protect all freely rotating parts by means of permanently installed guards/ covers against unintentional contact and falling down objects.**
 - **To avoid sparks, the covers for couplings used should be made of stainless steel!**
 - **As a minimum, the covers have to fulfil the requirements of protection type IP2X.**
 - **The covers have to be designed to prevent dust from depositing on the coupling.**
 - **The cover must not contact the coupling or impair the proper function of the coupling.**
-
- Make sure that the speeds, torques and ambient temperatures as stated in chapter 6 'Technical Data' are not exceeded.
 - The maximum permissible bore diameters must not be exceeded.
 - Check whether the shaft-hub connections safely transmit the occurring operating torques.
 - The standard tolerance of RINGFEDER® TNS for finish bores is fit H7.
 - Standard keyways comply with DIN 6885, sheet 1.
 - Check the dimensions and tolerances of shafts, hub bores, keys and keyways.
 - Set screws as required.

7.2 Finish bores

The following procedure has to be observed to produce a finish bore in a coupling hub:

- Clean and remove all preservatives from the coupling hub.
- Mount the coupling hub between the surfaces marked with Γ and carefully align the coupling hub according to the claw pattern.
- The values for $\varnothing d_{1max}$ listed in table 1 are valid for keyed connections according to DIN 6885/1 and must not be exceeded.
- Select the bore fit so that an interference fit such as H7/m6 results when mating it with the shaft tolerance.
- Axially lock the hub, for example by means of a setscrew on the back of the hub above the keyway

Consult RINGFEDER POWER TRANSMISSION in case of other shaft-hub connections.



- **The stated maximum bore diameters are valid for keyed connections according to DIN 6885/1 and must not be exceeded.**
- **If these values are exceeded, the coupling can break.**
- **Flying off coupling fragments are a danger to life!**

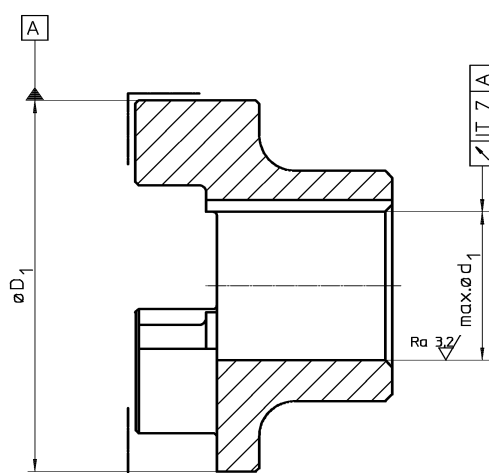

7.3 Coupling installation

- Remove the elastic buffer ring (Fig. 3, pos. 1).
- Prior to installation, carefully clean the bore of the coupling hub and the shaft end. The surfaces must be clean, dry and free of grease.
- For larger couplings use suitable mounting tools and hoisting devices such as cranes or pulley blocks.
- Mount the coupling hub in the proper position on the shaft end (Fig. 3, pos. 2).

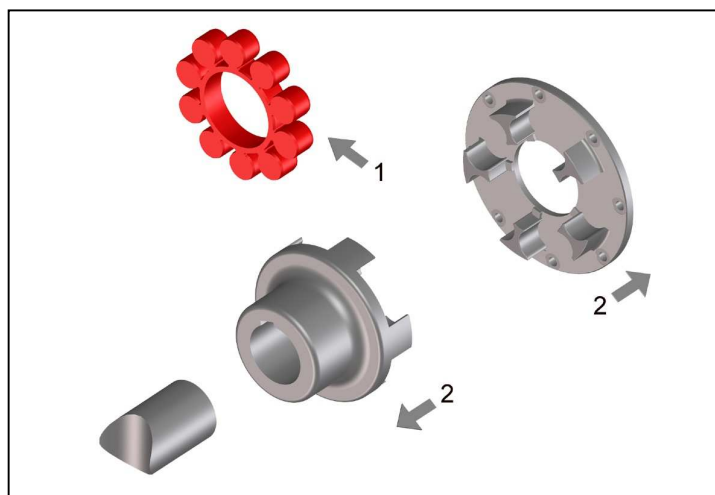

Fig. 3

Note:

To facilitate mounting, the hub can be uniformly heated to 80°C to 120°C.



- **Warning!**
- **Always wear heat-resistant gloves to protect yourself against injuries due to hot coupling components!**

- Mount the hub in such a manner that the shaft end is flush with the inner bore opening (Fig. 4). Observe deviant agreements, which may exist!
- When tightening setscrews, secure them with an adhesive, such as e.g. Loctite 222, to prevent the screws from working loose and dropping out.
- Mount the aluminium coupling flange to the flange connection. When joining the parts, take care that they do not get canted at the centering seat. (Fig. 3, pos. 2).

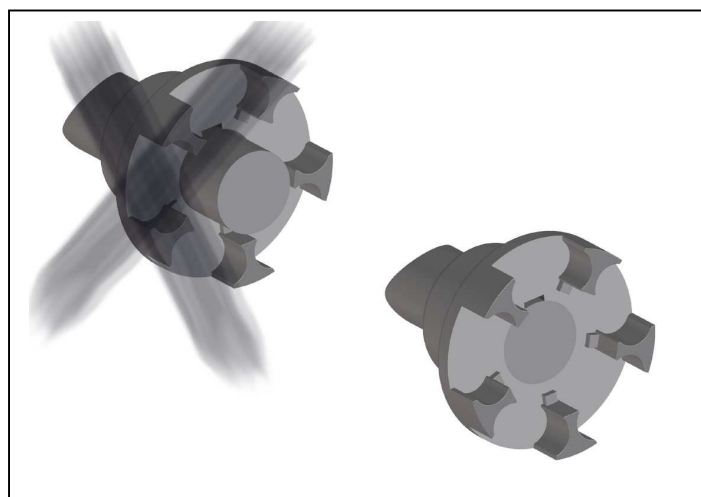

Fig. 4

ATTENTION!

The contact surfaces of the coupling hub and flange connection must be clean, dry and free of grease. Balanced parts are match marked to each other.

Let the hot hub cool down to ambient temperature, before inserting the buffer ring.

- To facilitate mounting, the buffer ring can be coated with a lubricant (for ex. talcum for Perbunan Pb, or commercial roller bearing grease for polyurethane Vk).
- Install the buffer ring on one of the coupling halves.
- Push together the shaft end with the mounted coupling half and the coupling flange (Fig. 5).
- Align the coupling in accordance with the instructions given in chapter 8 'Coupling Alignment'.

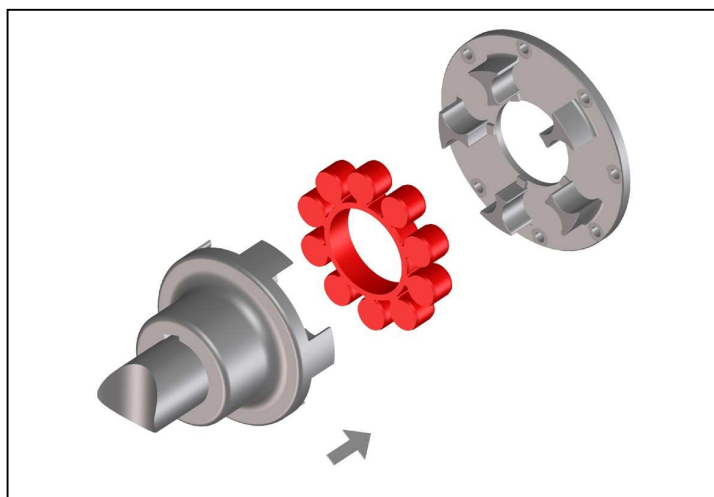

Fig. 5

8 Coupling Alignment



- **Danger of Injuries!**
 - **Disconnect the drive before carrying out any work on the coupling.**
 - **Secure the drive against unintentional re-start and rotation!**
 - **Note:**
 - **Accurate alignment of the coupling prolongs the lifetime of the elastic buffer ring.**
 - **It is of utmost importance to observe the recommended alignment values. Exceeding the permissible misalignment values results in coupling damages and failures!**
-
- When aligning the cold equipment take into account the expected thermal growth of the components, so that the permissible misalignment values for the coupling are not exceeded in operation.
 - Be aware that the coupling under misalignment imposes restoring forces on the adjacent shafts and bearings. Take into account that the larger the misalignment, the greater the restoring forces will be.
 - The maximum permissible misalignments stated in tables 2 to 4 are guiding values. We recommend utilizing these values up to 50 % only when aligning the coupling, so as to have sufficient reserves for thermal growth, foundation settlements etc. during service. In special applications with high demands on quiet running characteristics or higher

speeds, alignment accuracies of $\leq 0,1$ mm may be necessary for the three alignment levels.

- If the coupling is mounted in a closed housing/ guard, so that alignment at a later point of time will no longer be possible, make sure that the geometry and the fitting accuracy of the contact surfaces ensure true alignment of the shafts within the specified tolerances during service.

8.1 Angular Misalignment

- Measure one complete revolution (360°) on the face of the outer diameter. Determine the largest deviation K_{w1} and the smallest deviation K_{w2} (Fig. 6). Calculate the angular misalignment:
 $\Delta K_w = K_{w1} - K_{w2}$.
- When aligning, observe the max. permissible angular misalignment $\Delta K_{w_{max}}$ acc. to table 2.
- The values are applicable for a reference speed of 1500 rpm.

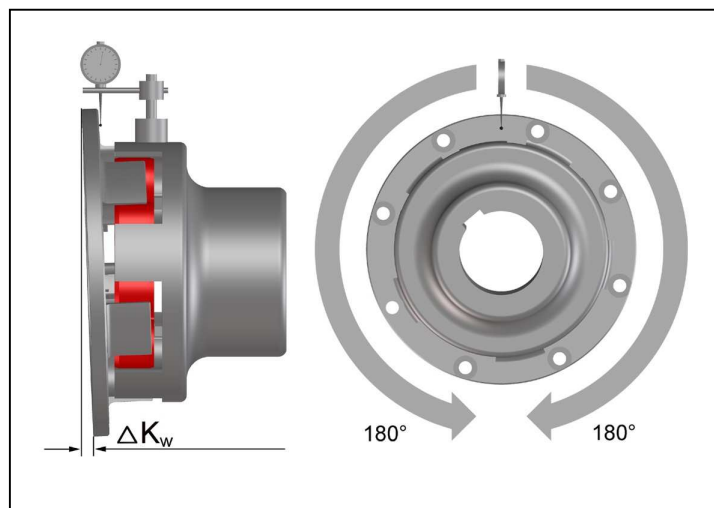

Fig. 6

Table 2 Maximum permissible angular misalignment values:

Size	100	125	145	170	200	230	260	300	360	400
$\Delta K_{w_{max}}$ [mm]	0,4	0,6	0,6	0,6	0,6	0,6	0,6	0,6	0,6	0,6

8.2 Radial Misalignment

- Measure one complete revolution (360°). Determine the largest deviation $Kr1$ and the smallest deviation $Kr2$ (Fig. 7). Calculate the radial misalignment: $\Delta Kr = 0,5 \times (Kr1 - Kr2)$. Observe the preceding sign of the measured values.
- When aligning, observe 50 % of the maximum permissible radial misalignment ΔKr_{max} acc. to table 3.
- The values are applicable for a reference speed of 1500 rpm.

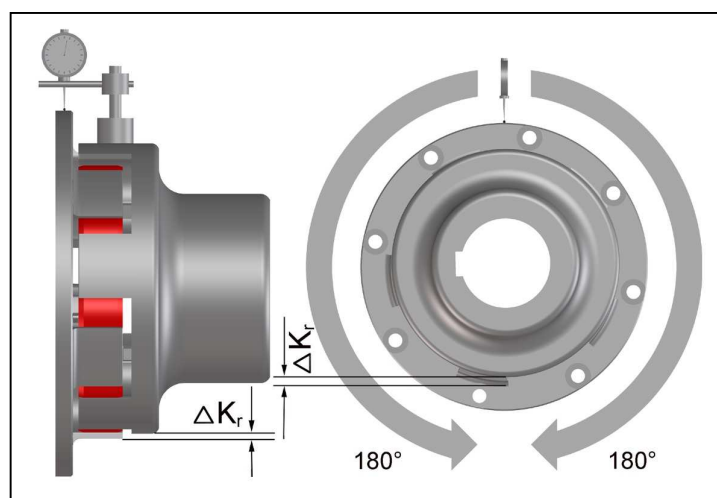

Fig. 7

Table 3 Maximum permissible radial misalignment values:

Size	100	125	145	175	200	230	260	300	360	400
ΔKr_{max} [mm]	0,6	0,7	0,7	0,7	0,8	0,8	0,9	0,9	1,0	1,0

8.3 Axial Misalignment

- Measure the axial claw overlap 'h' as shown in Fig. 8.
- The dimension of h must be in between the values h_{min} and h_{max} stated in table 4.

ATTENTION!

Consult RINGFEDER POWER TRANSMISSION if larger axial misalignments are expected during operation.

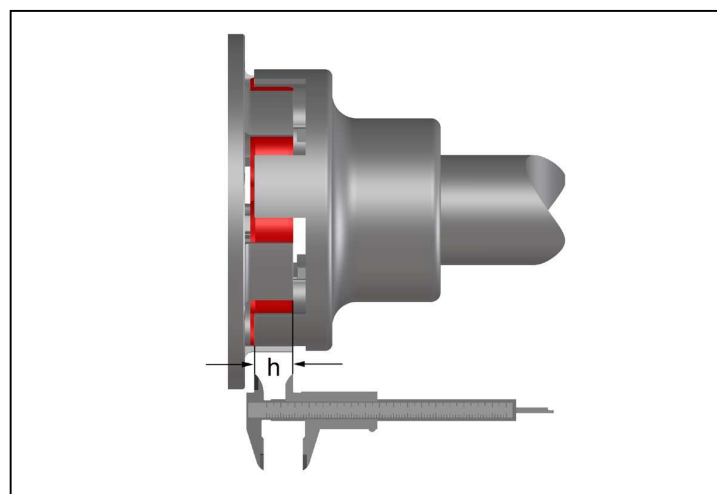

Fig. 8

Table 4 Recommended axial alignment values:

Size	100	125	145	170	200	230	260	300	360	400
h_{max} [mm]	20	25	30	30	35	35	45	50	55	55
h_{min} [mm]	18	22,5	27,5	27	32	31,5	41	46	51	51

9 Operation

When operating the coupling, its specific technical data have to be carefully observed (see chapter 6 ‘Technical Data’). These values must never be exceeded without the prior written approval by RINGFEDER POWER TRANSMISSION.

In order to ensure trouble-free and reliable performance of the coupling, the coupling has to be designed according to the selection specifications, e.g. according to DIN 740, part 2, (or acc. to Paper & Tech Paper “Elastomer Jaw Couplings”), with a service factor appropriate to the service conditions. Any change in the service conditions or service parameters always necessitates the verification of the coupling design.



- **Danger of injuries!**
- **Disconnect the drive before carrying out any work on the coupling!**
- **Secure the drive against unintentional re-start and rotation!**
- **Improperly tightened screws may cause parts to fly off what leads to most serious personal injuries and property damages!**
- **Before putting the coupling into operation, check the alignment and all screwed connections for correct tightening torque and firm fit!**

- **Before starting up the equipment, install all protective guards in order to avoid unintentional contact with freely moving or rotating parts.**
- **To avoid sparks, the covers for couplings used should be made of stainless steel!**
- **The covers have to comply with protection type IP2X as a minimum.**
- **The cover shall be designed to prevent dust from depositing on the coupling parts.**
- **The cover must not touch the coupling and impair the proper operation of the coupling.**
- **For equipment group I in mining applications, pay careful attention to the particular hazards that exist when using aluminium parts!**

While operating the coupling, pay attention to:

- Changes in operation noises
- Occurring vibrations

Attention!

- **Disconnect the drive immediately, if any irregularities are observed while operating the coupling!**
- Identify the cause for the problem using table 5 “Operation Faults and Possible Causes” and correct the fault.
The listed problems are some examples to assist you in troubleshooting.
- **All the machinery components and operation modes have to be considered for the determination and correction of faults!**

Table 5 Operation Faults and Possible Causes:

Trouble	Cause	Risk Warning	Correction
Irregular running noises/ vibrations	Alignment fault	Considerable increase in coupling temperature. Premature wear of elastic buffers. Increased reaction forces act on connected machines.	<ul style="list-style-type: none"> - Disconnect drive - Remove cause for alignment fault - Re-align coupling - Inspect elastomer for wear
	Elastomer worn out	Coupling claws strike against each other. Spark formation, claw fracture, increased reaction forces.	<ul style="list-style-type: none"> - Disconnect drive - Check coupling components for damages and replace parts, if necessary - Replace elastomer
	Unbalance	Considerable increase in coupling temperature. Premature wear of elastic buffers. Increased reaction forces act on connected machines	<ul style="list-style-type: none"> - Disconnect drive - Verify balance state of plant components and correct it, if necessary - Inspect elastomer for wear
	Loose screw connections	Flying off parts can cause serious injuries and considerable damages.	<ul style="list-style-type: none"> - Disconnect drive - Check coupling parts for damages, replace parts, if necessary - Verify alignment of coupling - Tighten screws to the specified tightening torque and secure them against working loose, if necessary, - Inspect elastomer for wear
Premature wear of elastomer	Alignment fault	Considerable increase in coupling temperature. Increased reaction forces act on connected machines.	<ul style="list-style-type: none"> - Disconnect drive - Remove cause for alignment fault - Re-align coupling - Inspect elastomer for wear
	Unacceptable temperatures	Material properties of elastic buffers change. The torque transmission capability is adversely affected.	<ul style="list-style-type: none"> - Disconnect drive - Replace elastomer - Re-align coupling - Adjust ambient temperature

Trouble	Cause	Risk Warning	Correction
	Contact with aggressive products	Material properties of elastic buffers change. The torque transmission capability is adversely affected.	<ul style="list-style-type: none"> - Disconnect drive - Check coupling parts for damages and replace parts, if necessary - Replace elastomer - Verify alignment of coupling - Prevent contact with aggressive products
	Torsional vibrations in the drive line	Considerable increase in coupling temperature. Premature wear of elastic buffers. Increased reaction forces act on connected machines.	<ul style="list-style-type: none"> - Disconnect drive - Analyse and eliminate cause for torsional vibrations - Check coupling parts for damages and replace parts, if necessary - Replace elastomer and consult RINGFEDER POWER TRANSMISSION concerning eventual use of another Shore-hardness - Verify coupling alignment
Claw breakage	Wear limit of elastomer exceeded ====> contact of claws	Coupling is destroyed. Connected machines can be affected, too.	<ul style="list-style-type: none"> - Disconnect drive - Replace coupling - Inspect the elastomer for wear at shorter intervals
	Overload due to too high torque	Coupling is destroyed. Connected machines can be affected, too.	<ul style="list-style-type: none"> - Disconnect drive - Verify coupling design in cooperation with RINGFEDER POWER TRANSMISSION - Replace coupling - Install larger coupling, if necessary

10 Maintenance

The flexible coupling RINGFEDER® TNS SX only requires little maintenance during operation. The elastic buffer ring is subject to wear. The time at which the wear limit of the elastic buffer ring is reached depends on the service parameters and application conditions.

On the occasion of routine inspections or maintenance of the equipment, check:

- alignment of coupling,
- state of the elastomer, and
- remove dust deposits from coupling parts and buffer ring.

10.1 Wear Inspection on the Buffer Ring



- **Danger of injuries!**
- **Disconnect the drive before carrying out any work on the coupling!**
- **Secure the drive against unintentional re-start and rotation!**

Perform a visual inspection and a wear inspection of the buffer ring after 2000 hours, or after 3 months at latest, after the first start-up of the equipment. If only minor wear or no wear is observed, further inspections of the plant can be carried out at regular intervals of 4000 hours, however, at least once a year, if the operating modes and conditions of the plant remain unchanged. However, should you observe excessive wear on the occasion of this first inspection already, check whether the cause for the problem is listed in table 5 “Operation faults and possible causes”. In such a case, the inspection intervals must be adapted to the prevailing service conditions.

On the occasion of routine inspections or maintenance work on the drive equipment, or after 3 years at latest:

- Replace the elastic buffer ring.
- If the wear limit has been reached or exceeded, replace the buffer ring immediately, irrespective of the inspection intervals of the equipment.
- Check the alignment of the coupling.
- Remove dust deposits from the coupling components and buffer ring.

10.2 Wear Inspection - Equipment at standstill

- Replace the elastic buffer ring as soon as the coupling has a distinct torsional backlash, or if the wear limit acc. to table 6 has been reached.
- To check the wear of the elastomer, the plant has to be shut down and must be unloaded. Turn the coupling halves in such a manner that the claws rest without clearance at the buffer of the elastic ring.
- Measure the claw distance 'V' in circumferential direction across the buffers to which the claws rest on both sides (see fig. 9). The adjacent buffers do not contact the claws.
- Repeat this measurement on the adjacent buffers after having turned the couplings halves against each other in opposed direction.
- If dimension 'V' attains or exceeds the value ' V_{min} ' listed in table 6 for the individual coupling sizes, the elastic buffer ring has to be replaced immediately.

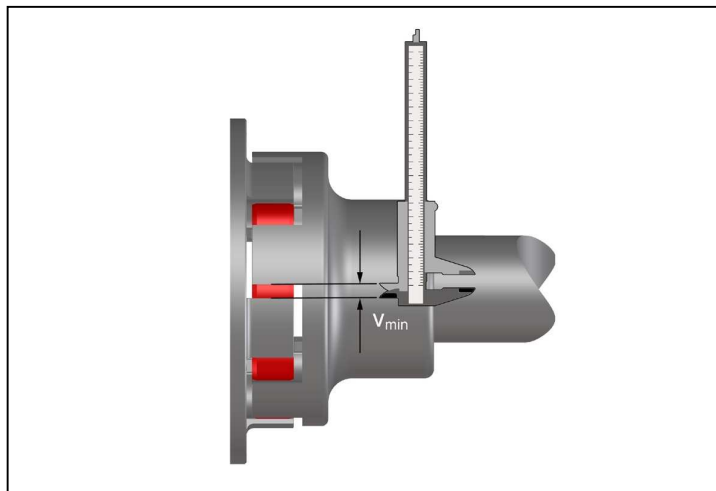

Fig. 9

Table 6 Distance dimension V_{min} for wear measurement while the equipment is at standstill:

Size	100	125	145	170	200	230	260	300	360	400
V_{min} [mm]	11,5	12,7	13,8	13,6	14,3	15,4	15,3	12,1	12,1	15,4

Upon completion of the wear measurement, re-install all the protective devices and covers.

10.3 Replacement of buffer ring



- **Danger of injuries!**
- **Disconnect the drive before carrying out any work on the coupling!**
- **Secure the drive against unintentional re-start and rotation!**

- Push back one of the coupling halves (Fig. 10).
- Remove the buffer ring (part 020).
- To facilitate mounting, the new buffer ring can be coated with a lubricant before installing it (e.g. talcum for Perbunan Pb, or commercial roller bearing grease for Polyurethane Vk).
- Mount a new buffer ring of correct material and size .
- Push the coupling halves together again.
- Align the coupling according to the instructions given in chapter 8 'Coupling Alignment'.

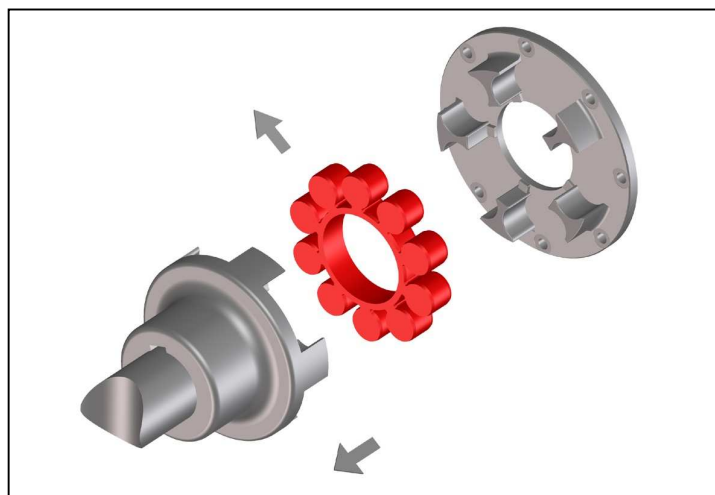

Fig. 10

Warning!



- **Before putting the equipment into service, all safety guards must be installed to prevent unintentional contact with freely rotating parts.**
- **To avoid sparks, the covers for couplings used should be made of stainless steel.**
- **The covers have to fulfil the requirements of protection type IP2X as a minimum.**
- **The covers have to be designed to prevent dust from depositing on the coupling parts.**
- **The cover must not touch the coupling and impair the proper operation of the coupling.**

We do not assume any responsibility or warranty for any damages resulting from the use of accessories or spare parts, which have not been originally manufactured by RINGFEDER POWER TRANSMISSION.

11 Disposal

Disposal of the parts must be arranged in accordance with the regulations and laws of the country where the equipment is installed.