



ZF POD

Pod Drive System

2500 & 2800 Series



Safety
Comfort
Efficiency
Maneuverability



Efficiency

The ZF POD is one of the most efficient propulsion system, ideal for medium-sized pleasure craft of 30 to 48 feet overall length, can be used with engines up to 450 hp.

The increased propulsion efficiency, compared to traditional shaft-line systems, can give up to 15% faster cruise speed and up to 15% faster top speed. Better performance translates into improved fuel economy up to 30%, environmental footprint reduction and both initial and through-life cost reduction. The system consists of a transmission unit, a steering system and counter-rotating propellers, governed by an electronic control system.

This Pod Drive System is a compact and light unit, best suited for the most popular sized pleasure crafts.



Joystick Maneuvering System



SmartCommand Control Head

Maneuverability

The ZF POD is controlled by ZF's SmartCommand control system and the JMS (Joystick Maneuvering System), which ensures easy and safe cruising and maneuvering.

Each pod moves independently, resulting in excellent turning efficiency and superb response. Reliable, smooth, electric power steers the pods and optional automated trim-tabs improve performance and trim angle during acceleration.

Patented tunnel installation gives to the boat exceptional stability when turning, due also to the vertical installation of the pod units.

A full range of propellers with different diameters

and pitch angles is available, making this system a perfect match for both planing and non-planing boats.

The drive can be matched to all types of diesel or gas engines within the approved power range.

The advanced Joystick Maneuvering System (JMS), developed by ZF, controls all ZF POD maneuvering functions. It is incredibly intuitive and can be operated with a simple turn of the wrist! One hand controls it all - sideways tracking, turning on the spot - all with precise speed control. The optional "iAnchor" function, thanks to an integrated GPS receiver, enables the vessel to be kept at an exact position and orientation at the press of a button.

Whether at the dock or backing down on a blue marlin, the total command and maneuverability is simply unmatched!

Safety

If the pod drive strikes underwater debris, aft-facing propellers are protected by the pod gearcase and skeg.

In addition, by mounting the ZF POD in a tunnel, the torpedo shape of the drive is the same depth as the keel. Most floating objects will be deflected downward by the keel and skeg, and therefore, away from the propellers.

Should the pod hit a substantial object, the skeg is designed to shear below the torpedo, minimizing damage to the drive and hence, costly repair bills!

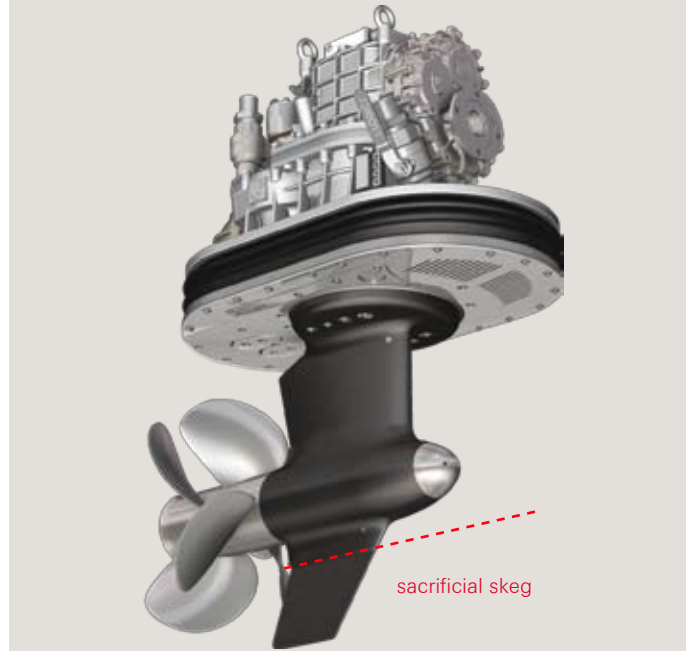

Comfort

The ZF POD uses counter-rotating propellers and is mounted on large rubber supports. Gear noise and vibration are significantly reduced, resulting in a quiet, comfortable ride.

The engine exhaust is nearly eliminated by venting through the propeller hubs so that the water flow takes it far back into the wake.



Selected features

- Drive by wire electrically actuated steering
- Joystick with proportional speed control
- Electronic throttle & shift control
- Electronically controlled trim-tabs
- Auto sync
- Single lever
- Dock mode
- Troll
- Warmup
- Keyswitch
- Display
- Required switch panels
- Gearcase with breakaway skeg
- One piece grommet
- Mercathode
- iAnchor

Available ratios and weight

Model	Ratios	Power/rpm		Input Power Capacity						Max Input Engine rpm	Weight									
		kW/rpm	hp/rpm	3000 rpm		3300 rpm		3800 rpm			kg	lb								
				kW	hp	kW	hp	kW	hp											
ZF POD 2500	2,01	2,138	2,236	0,073	0,098	219	294	241	323	277	372	5000	240	528						
	1,495	1,59	1,663	0,098	0,131	294	393	323	432	372	498				3800	260	573			
	1,752	1,864	1,949	0,084	0,113	252	339	277	373	319	429							4400	260	573
	2,01	2,138	2,236	0,073	0,098	219	294	241	323	277	372									
2,26	2,405	2,515	0,065	0,087	195	261	215	287	247	331	5600	260	573							
ZF POD 2800-1	1,495	1,59	1,663	0,107	0,145	321	436	353	480					3800	260	573				
	1,752	1,864										4400	260				573			

Note: Please verify engine compatibility with ZF Marine local distributors