

Turbine Series - 75900/1000FHX

FUEL

Specifications:

Diesel Applications

Height: 75900FHX: 16.5" (41.9 cm)
751000FHX: 21.8" (55.4 cm)

Width: 18.75" (47.6 cm) with Bracket

Depth: 10.8" (27.4 cm) with Bracket

Dry Weight: 75900FHX: 23.0 lbs (10.4 kg)
751000FHX: 30 lbs (13.6 kg)

Valve Male Fittings:
7/8"-14 UNF-2A (SAE J514 37° Flare)

Service Clearance (Top):
75900FHX: 5.0" (12.7 cm)
751000FHX: 10.0" (25.4 cm)

Vacuum Installation Recommended
Maximum Head Pressure: 15 psi (1.03 bar)

Max Flow Rate:
75900FHX: 180 gph (682 lph)
751000FHX: 360 gph (1362 lph)

Create a Part Number

Housing Type	Filter Model	Valve Type	Filtration Rating
Dual Assembly	Turbine Model 90/180 GPH Flow Rate	6-Port Ball Valve	2 micron
75	Turbine Model 180/360 GPH Flow Rate	X	10 micron
	900FH 1000FH		30 micron

RACOR®

Dimensions:

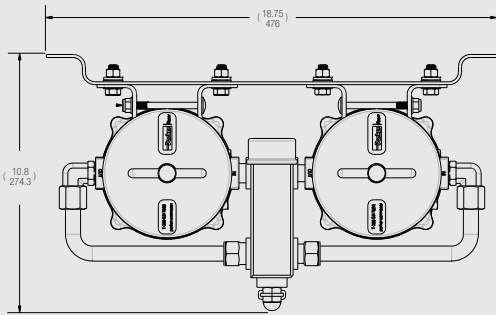

75900FHX/751000FHX Top

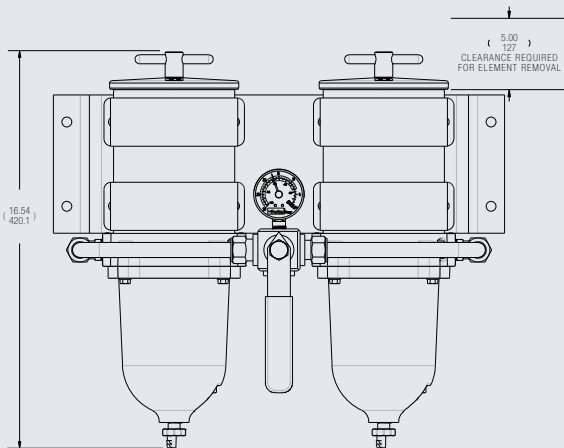

75900FHX Front

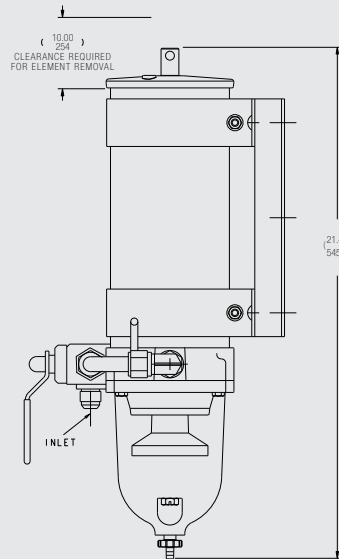

751000FHX Profile

ASSEMBLY	DESCRIPTION
75900FHX2	Dual 900 Turbine Assy., 2 micron Filter
75900FHX10	Dual 900 Turbine Assy., 10 micron Filter
75900FHX30	Dual 900 Turbine Assy., 30 micron Filter
751000FHX2	Dual 1000 Turbine Assy., 2 micron Filter
751000FHX10	Dual 1000 Turbine Assy., 10 micron Filter
751000FHX30	Dual 1000 Turbine Assy., 30 micron Filter

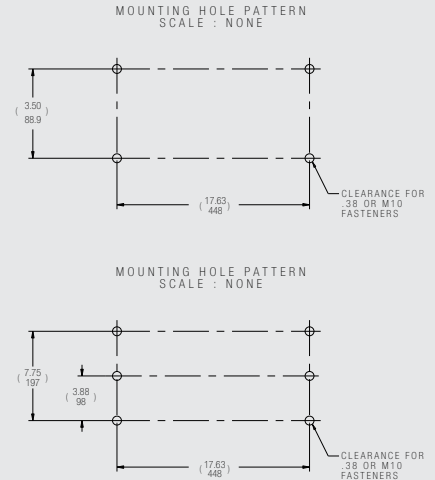

DUAL ASSEMBLIES



PARTS

Turbine Series - 75900/1000FHX

1

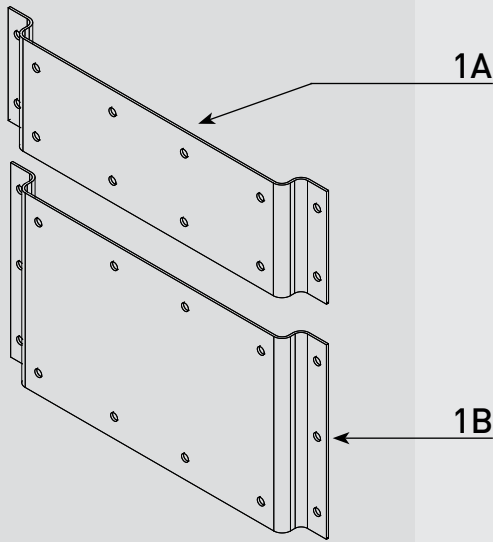

2

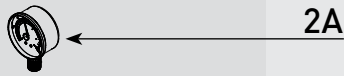

3

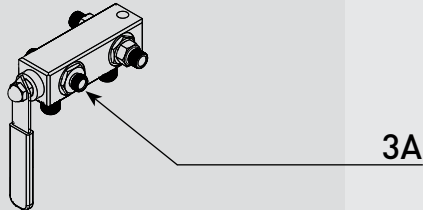

4

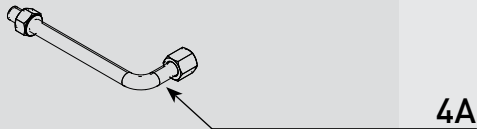

5

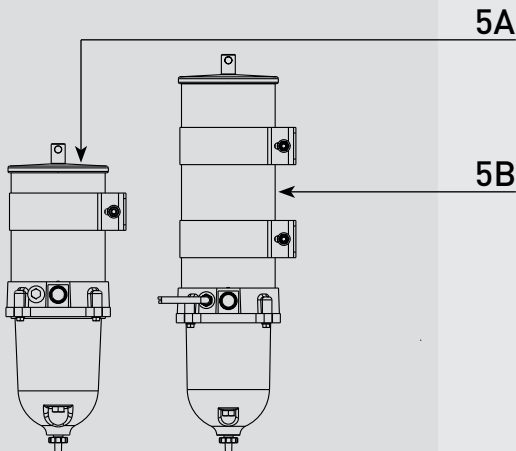

See **RSL0292**
For 900FH/1000FH Parts Breakdown

Part #	Description
1A	Mounting Bracket - 75900FHX - Bracket only
1B	Mounting Bracket - 751000FHX - Bracket only
2A	RK19669 RK19667 Vacuum Gauge (30" Hg) - 3 needles: Theshold (red), Max Change Out (Red - Adjustable), Gauge (Black) <i>Optional</i> - Compound Gauge Kit (Vacuum 30" HG / Pressure 15psi)
3A	RK 19473 RK 19506 6-Port Ball Valve Valve Service Kit - Includes Handle/Stem/O-rings/Gasket
4A	RK 19475 Rigid Tubing Kit - Includes (1ea.) Tube, Ferrule and Fitting
5A	Turbine Fuel Filter - 900FH Series See Cutsheet RSL0292 for available Parts and Accessories
5B	Turbine Fuel Filter - 1000FH Series See Cutsheet RSL0292 for available Parts and Accessories

Accessories and Parts Available (Not Shown)

6A	RK 11-1952 RK 11-1404 Complete Seal Service Kit - 900FH/1000FH Series Filters (Requires 2) Complete Seal Service Kit - 900/1000 Series Filters For FG and Older Models (Requires 2)
6B	RK30880E WIF Sensor and Light Kit - 1/2"-20 UNF
6C	RK 14329 RK 14321 Water Detection Module - 12 vdc Water Detection Module - 24 vdc
7A	Bowl Gasket - Included in 6A
7B	RK 11-1938 Bowl Kit - Includes 7A, 7C & 7E
7C	RK 20126 Bowl Plug (O-ring Included in 6A)
7D	RK33802 WIF Probe Kit - 1/2"-20 UNF - Two Wire Pigtail Water Detection Module Required - Use 6C
7E	Self-venting Drain (O-ring Included in 6A)
8A	2040V2 2040V10 2040V30 900FH Replacement Element 2 micron 900FH Replacement Element 10 micron 900FH Replacement Element 30 micron
8B	2020V2 2020V10 2020V30 1000FH Replacement Element 2 micron 1000FH Replacement Element 10 micron 1000FH Replacement Element 30 micron

Valve Operations

