



SHURFLO[®]

MARINE PRODUCT

CATALOG INTERNATIONAL

MARINE plumbing system

SHURFLO has been the marine industry's leading plumbing supplier for more than 35 years. Through innovative product design, superior service and close customer relationships, SHURFLO's solutions support the growth of the marine industry and ensure the satisfaction of boaters around the world.

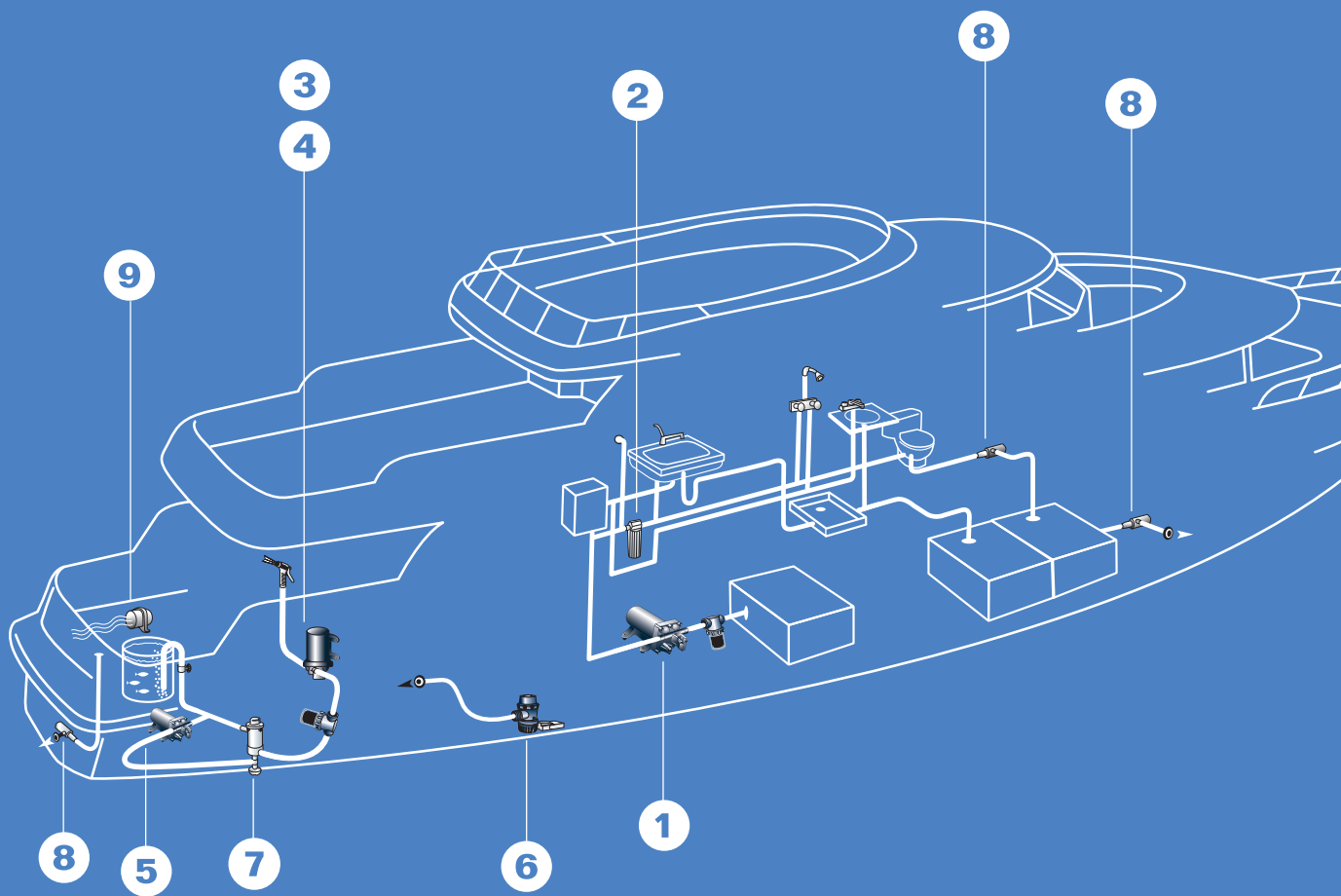

CONTENTS

2-3
Fresh Water
Pumps

4-5
Washdown
Pumps

6
Livewell
Pumps

7
Bilge
Pumps

8
Marine Blowers &
Macerator Pumps

All Major Plumbing Components

1 AQUA KING™ II
Fresh Water Pumps

2 WATERguard™
FILTRATION
EVERPURE®
Water Filtration

3 BLASTER™ II
Washdown Pumps

4 PRO BLASTER™ II
Washdown Pumps

5 PRO BAITMASTER™ II
Livewell Pumps

6 SHURFLO®
Bilge Pumps

7 BAIT SENTRY™
Livewell Pumps

8 MACERATOR
Sanitation & Fish Box Evacuation

9 yellowTAIL™
In-Line Blower
Marine Blowers

9
Utility
Pumps

10-11
Water System
Accessories

11
Water
Filtration

12
Pump
Fittings

13-17
Pump Repair &
Rebuild Kits

18-20
Installation
Guidelines

FRESH WATER



AQUA KING™ II FRESH WATER PUMPS JUNIOR 2.0 GPM & STANDARD 3.0 GPM



SHURFLO's 4129 and 4139 series fresh water pump design were created with unique over-molded single-piece diaphragm and internal by-pass (3.0 version only), assuring long life and top performance in all plumbing systems. Designed as the next legendary pump to exceed the expectations of our customers, the 4129 and 4139 series pumps are constructed for smooth flow and no rapid cycling. SHURFLO's quality reputation has been built on the reliability and dependability of every pump we build. The 4129 and 4139 series fresh water automatic demand pumps are quiet, thermally protected and can run dry without damage. **3 Year Warranty**

Name	Model # OEM/Aftermarket	Description	Voltage	Dimensions	Flow Rate	Amps (Max.)	Shut-Off Pressure
AQUA KING™ II Junior 2.0	4129-110-A02 4129-110-B02	Intermittent Duty up to two Fixtures	12 VDC	8.2" x 4.9" x 4.1" [208 x 124 x 104mm]	2.0 GPM [7.6 LPM]	3	20 PSI [1.4 BAR]
AQUA KING™ II Standard 3.0	4139-111-A54 4139-111-B54	Intermittent Duty Multi-Fixture Application	12 VDC	8.2" x 4.9" x 4.1" [208 x 124 x 104mm]	3.0 GPM [11.3 LPM]	4.5	30 PSI [2.0 BAR]
AQUA KING™ II Standard 3.0	4139-111-A87 4139-111-B87	Intermittent Duty Multi-Fixture Application	12 VDC	8.2" x 4.9" x 4.1" [208 x 124 x 104mm]	3.0 GPM [11.3 LPM]	5.3	45 PSI [3.1 BAR]
AQUA KING™ II Standard 3.0	4139-131-B54	Intermittent Duty Multi-Fixture Application	24 VDC	8.2" x 4.9" x 4.1" [208 x 124 x 104mm]	3.0 GPM [11.3 LPM]	2.5	30 PSI [2.0 BAR]
AQUA KING™ II Standard 3.0	4139-131-A87 4139-131-B87	Intermittent Duty Multi-Fixture Application	24 VDC	8.2" x 4.9" x 4.1" [208 x 124 x 104mm]	3.0 GPM [11.3 LPM]	3	45 PSI [3.1 BAR]



AQUA KING™ II FRESH WATER PUMPS 4.0



SHURFLO's AQUA KING™ II Fresh Water Pumps are designed for boats with multi-fixtures providing "Just like home" shower pressure, and can operate at lower flow conditions with low cycling. A built in mechanical bypass function enables these pumps to vary the flow rate for any on demand condition, without the need for an accumulator. With heavy duty motors built to withstand the tough marine environment these motors feature an electro-coated seamless shell motor, O-ring sealed end bells, and complete sealed wire entries on the motor shell and pressure switch. The AQUA KING™ II Fresh Water Pumps can run dry without damage. Inlet strainer and 1/2" hose barb fittings are included (aftermarket models only). Ignition protected. Thermally protected.

3 Year Warranty

Name	Model # OEM/Aftermarket	Description	Voltage	Dimensions	Flow Rate	Amps (Max.)	Shut-Off Pressure
AQUA KING™ II Premium 4.0	4149-153-A86 4149-153-B86	Intermittent Duty Multi-Fixture Application	12 VDC	10" x 5" x 4.75" [254 x 127 x 120mm]	4.0 GPM [15.1 LPM]	10	40 PSI [2.8 BAR]
AQUA KING™ II Premium 4.0	4148-153-A75 4148-153-E75	Intermittent Duty Multi-Fixture Application	12 VDC	10" x 5" x 4.75" [254 x 127 x 120mm]	4.0 GPM [15.1 LPM]	10	55 PSI [3.8 BAR]
AQUA KING™ II Premium 4.0	4148-163-A75 4148-163-E75	Intermittent Duty Multi-Fixture Application	24 VDC	10" x 5" x 4.75" [254 x 127 x 120mm]	4.0 GPM [15.1 LPM]	5	55 PSI [3.8 BAR]



AQUA KING™ II FRESH WATER PUMPS 5.0



SHURFLO's AQUA KING™ II Fresh Water Pumps are designed for boats with multi-fixtures providing "Just like home" shower pressure, and can operate at lower flow conditions with low cycling. A built in mechanical bypass function enables these pumps to vary the flow rate for any on demand condition, without the need for an accumulator. With heavy duty motors built to withstand the tough marine environment these motors feature an electro-coated seamless shell motor, O-ring sealed end bells, and complete sealed wire entries on the motor shell and pressure switch. The AQUA KING™ II Fresh Water Pumps can run dry without damage. Inlet strainer and 1/2" hose barb fittings are included (aftermarket models only). Ignition protected. Thermally protected.

3 Year Warranty

Name	Model # OEM/Aftermarket	Description	Voltage	Dimensions	Flow Rate	Amps (Max.)	Shut-Off Pressure
AQUA KING™ II Supreme 5.0	4158-153-A75 4158-153-E75	Intermittent Duty Multi-Fixture Application	12 VDC	10" x 5" x 4.75" [254 x 127 x 120mm]	5.0 GPM [18.9 LPM]	13	55 PSI [3.8 BAR]
AQUA KING™ II Supreme 5.0	4158-163-A75 4158-163-E75	Intermittent Duty Multi-Fixture Application	24 VDC	10" x 5" x 4.75" [254 x 127 x 120mm]	5.0 GPM [18.9 LPM]	7	55 PSI [3.8 BAR]

pumps

AQUA KING™ FRESH WATER PUMPS

CE

SHURFLO AQUA KING™ pumps deliver quiet operation and smooth performance while providing the ultimate in durability and reliability. Designed and built specifically for the harsh marine environment, these freshwater pumps are equipped with sealed switches and seamless e-coated motors. Thermally Protected. Ignition Protected. **3 Year Warranty**



Name	Model # OEM/Aftermarket	Description	Voltage	Dimensions	Flow Rate	Amps (Max.)	Shut-Off Pressure
AQUA KING™ Junior 2.0	2901-0202 2901-0212	Intermittent Duty Up to 2 Fixtures	12 VDC	7.3" x 5.0" x 4.6" [184 x 127 x 118mm]	2.0 GPM [7.6 LPM]	3.4	20 PSI [1.4 BAR]
AQUA KING™ Junior 2.0	2901-0203 2901-0213	Intermittent Duty Up to 2 Fixtures	12 VDC	7.3" x 5.0" x 4.6" [184 x 127 x 118mm]	2.0 GPM [7.6 LPM]	3.6	30 PSI [2.0 BAR]
AQUA KING™ Standard 3.0	3901-0203 3901-0213	Intermittent Duty Multi-Fixture Application	12 VDC	7.3" x 5.0" x 4.6" [184 x 127 x 118mm]	3.0 GPM [11.3 LPM]	5	30 PSI [2.0 BAR]
AQUA KING™ Standard 3.0	3901-0204 3901-0214	Intermittent Duty Multi-Fixture Application	12 VDC	7.3" x 5.0" x 4.6" [184 x 127 x 118mm]	3.0 GPM [11.3 LPM]	5.2	45 PSI [3.0 BAR]
AQUA KING™ Standard 3.0	3901-1213	Intermittent Duty Multi-Fixture Application	24 VDC	7.3" x 5.0" x 4.6" [184 x 127 x 118mm]	3.0 GPM [11.3 LPM]	2.5	30 PSI [2.0 BAR]
AQUA KING™ Standard 3.0	3901-1204 3901-1214	Intermittent Duty Multi-Fixture Application	24 VDC	7.3" x 5.0" x 4.6" [184 x 127 x 118mm]	3.0 GPM [11.3 LPM]	2.6	45 PSI [3.0 BAR]

HIGH FLOW SYSTEMS

CE

The most advanced systems available. These fully-automatic, quiet units deliver water smoothly and consistently. **3 Year Warranty**



Name	Model # OEM/Aftermarket	Description	Voltage	Flow Rate	Amps (Max.)	Shut-Off Pressure
HIGH FLOW SYSTEM	4558-153-E75 4558-153-E75	12 VDC High Flow System AQUA KING™ II Supreme 5.0 GPM and PRO BLASTER™ II Ultimate 5.0 GPM, Manifold assembly and Mounting Board	12 VDC	10.0 GPM [37.8 LPM]	13/11	55 PSI [3.8 BAR]
HIGH FLOW SYSTEM	4558-163-E75 4558-163-E75	24 VDC High Flow System AQUA KING™ II Supreme 5.0 GPM and PRO BLASTER™ II Ultimate 5.0 GPM, Manifold assembly and Mounting Board	24 VDC	10.0 GPM [37.8 LPM]	7/6	55 PSI [3.8 BAR]

SLV PUMP

CE

This compact automatic demand pump offers durability and dependability making it ideal for low volume, intermittent duty applications. The SLV Pump self-priming up to 2.5 vertical feet while delivering 1.0 GPM. A 12 volt low power consumption motor, equipped with a thermal protector and long life pressure switch rated to 30 PSI, provides high pump performance and reliability.

1 Year Warranty



Name	Model # OEM/Aftermarket	Description	Voltage	Dimensions	Flow Rate	Amps (Max.)	Shut-Off Pressure
SLV	105-013	Automatic Demand Pump	12 VDC	6.8" x 3.9" x 2.5" [170 x 100 x 60mm]	1.0 GPM [3.8 LPM]	2.5	30 PSI [2.0 BAR]

WASHDOWN pumps

CE BLASTER™ II WASHDOWN PUMPS



SHURFLO's New 4238 series washdown pump design was created with a unique over-molded single-piece diaphragm, assuring long life and top performance in all deck wash down plumbing systems. Designed as the next legendary pump to exceed the expectations of our customers, the BLASTER™ II Series pumps are designed for the toughest marine wash down applications. SHURFLO's quality reputation has been built on the reliability and dependability of every pump we build. The BLASTER™ II Series wash down automatic demand pumps are thermally protected and can run dry without damage. Fittings and nozzle included (aftermarket models only). Ignition protected. **2 Year Warranty**

Name	Model # OEM/Aftermarket	Voltage	Dimension	Flow Rate	Amps (Max.)	Shut-Off Pressure
BLASTER™ II	4238-121-A07 4238-121-E07	12 VDC	9.0" x 4.9" x 4.1" [229 x 124 x 104mm]	3.5 GPM [13.2 LPM]	7.5	45 PSI [3.1 BAR]
BLASTER™ II	4238-141-A07 4238-141-E07	24 VDC	9.0" x 4.9" x 4.1" [229 x 124 x 104mm]	3.5 GPM [13.2 LPM]	3.5	45 PSI [3.1 BAR]

CE PRO BLASTER™ II WASHDOWN PUMPS



A

SHURFLO's PRO BLASTER™ II Washdown Pumps deliver superior performance that customers have come to expect and rely upon. Whether its blasting away the grimeiest decks clean, fish box scaling and anchor chain cleaning, SHURFLO's PRO BLASTER™ II Washdown pumps deliver high performance that provide a powerful consistent spray pattern. Built to withstand the marine environment with electro-coated motor, O-ring seals, fully sealed wire entries and can run dry without damage. Inlet strainer, fittings and nozzle included (aftermarket models only). Ignition protected. Thermally protected. **2 Year Warranty**

Name	Model # OEM/Aftermarket	Voltage	Dimension	Flow Rate	Amps (Max.)	Shut-Off Pressure
PRO BLASTER™ II Deluxe 4.0 (A)	4248-153-A09 4248-153-E09	12 VDC	10" x 5.0" x 4.75" [254 x 127 x 120mm]	4.0 GPM [15.1 LPM]	10	60 PSI [4.1 BAR]
PRO BLASTER™ II Deluxe 4.0 (A)	4248-163-A09 4248-163-E09	24 VDC	10" x 5.0" x 4.75" [254 x 127 x 120mm]	4.0 GPM [15.1 LPM]	5	60 PSI [4.1 BAR]
PRO BLASTER™ II Ultimate 5.0 (B)	4258-153-A09 4258-153-E09	12 VDC	10" x 5.0" x 4.75" [254 x 127 x 120mm]	5.0 GPM [18.9 LPM]	14	60 PSI [4.1 BAR]
PRO BLASTER™ II Ultimate 5.0 (B)	4258-163-A09 4258-163-E09	24 VDC	10" x 5.0" x 4.75" [254 x 127 x 120mm]	5.0 GPM [18.9 LPM]	7	60 PSI [4.1 BAR]



B

PRO WASHDOWN KIT™ II

CE

SHURFLO's PRO WASHDOWN KIT™ II is available in both Deluxe 4.0 and Ultimate 5.0 series. These washdown kits include everything you need for those tough applications in fish box, scaling, anchor chain cleaning and blasting down the grimeiest decks all in one kit! The kits include a washdown pump (Deluxe 4.0 or Ultimate 5.0), Fittings, Nozzle, Raw Water Strainer and a 25' coiled hose.

2 Year Warranty *Coiled hose also available separately.

Name	Model # OEM/Aftermarket	Description	Dimension	Voltage	Flow Rate	Amps (Max.)	Shut-Off Pressure
PRO WASHDOWN KIT™ II Deluxe 4.0 (A)	4348-153-A09 4348-153-E09	PRO BLASTER™ II Deluxe, 4.0 Pump, Fittings, Nozzle, Raw Water Strainer, 25' 3/8" coiled hose	10" x 5.0" x 4.75" [254 x 127 x 120mm]	12 VDC	4.0 GPM [15.1 LPM]	10	60 PSI [4.1 BAR]
PRO WASHDOWN KIT™ II Ultimate 5.0	4358-153-A09 4358-153-E09	PRO BLASTER™ II Ultimate, 5.0 Pump, Fittings, Nozzle, Raw Water Strainer, 25' 1/2" coiled hose	10" x 5.0" x 4.75" [254 x 127 x 120mm]	12 VDC	5.0 GPM [18.9 LPM]	14	60 PSI [4.1 BAR]



A

RAW WATER STRAINERS

CE

SHURFLO's family of Raw Water Strainers are built to keep your bait tank, livewell and washdown pumps protected from harmful debris. The Raw Water Strainer features a clear twist off bowl and removable stainless steel screen, which allows for easy inspection and cleaning. An integral o-ring creates a tight seal, eliminating possible leaks. Keep your pumps and components lasting longer by protecting them with the SHURFLO Raw Water Strainer. **1 Year Warranty**

Name	Model # OEM/Aftermarket	Description
1/2" Strainer (A)	253-120-00 253-120-01	50 Mesh Screen. Protects Pumps from Harmful Debris, High Capacity, Rugged Nylon Housing with Clear Twist Off Polyamide Bowl and Easy to Clean Slide Out Screen
1/2" Strainer with bracket & fittings	253-121-01 253-121-01	50 Mesh Screen. Protects Pumps from Harmful Debris, High Capacity, Rugged Nylon Housing with Clear Twist Off Polyamide Bowl and Easy to Clean Slide Out Screen
3/4" Strainer	253-220-00 253-220-01	50 Mesh Screen. Protects Pumps from Harmful Debris, High Capacity, Rugged Nylon Housing with Clear Twist Off Polyamide Bowl and Easy to Clean Slide Out Screen
3/4" Strainer with bracket & fittings	253-221-01 253-221-01	50 Mesh Screen. Protects Pumps from Harmful Debris, High Capacity, Rugged Nylon Housing with Clear Twist Off Polyamide Bowl and Easy to Clean Slide Out Screen
1" Strainer (B)	253-320-00 253-320-01	50 Mesh Screen. Protects Pumps from Harmful Debris, High Capacity, Rugged Nylon Housing with Clear Twist Off Polyamide Bowl and Easy to Clean Slide Out Screen
1" Strainer with bracket & fittings	253-321-01 253-321-01	50 Mesh Screen. Protects Pumps from Harmful Debris, High Capacity, Rugged Nylon Housing with Clear Twist Off Polyamide Bowl and Easy to Clean Slide Out Screen
1-1/4" Strainer	253-400-00 253-400-01	20 Mesh Screen. Protects Pumps from Harmful Debris, High Capacity, Rugged Nylon Housing with Clear Twist Off Polyamide Bowl and Easy to Clean Slide Out Screen
1-1/4" Strainer with bracket & fittings	253-401-01 253-401-01	20 Mesh Screen. Protects Pumps from Harmful Debris, High Capacity, Rugged Nylon Housing with Clear Twist Off Polyamide Bowl and Easy to Clean Slide Out Screen



A



B

LIVEWELL

pumps



PRO BAITMASTER™ II LIVEWELL PUMPS



The SHURFLO PRO BAITMASTER™ II Heavy Duty Livewell/Washdown Pumps are excellent for live-well or washdown applications in harsh marine environments. The seamless motor shell and sealed switch protects the pump from splashed liquids. Self-priming and can run dry without damage. For tank size 35 gallons and under. Thermally protected. Ignition protected. **2 Year Warranty**

Name	Model # OEM/Aftermarket	Description	Voltage	Dimensions	Flow Rate	Amps (Max.)	Shut-off Pressure
PRO BAITMASTER™ II	4648-153-A07 4648-153-E07	12 VDC Continuous Duty, Splash Proof, Sealed Motor, ignition Protected	12 VDC	10" x 5.0" x 4.75" [254 x 127 x 120mm]	4.0 GPM [15.1 LPM]	8	45 PSI [3.1 Bar]
PRO BAITMASTER™ II	4648-163-A07 4648-163-E07	24 VDC Continuous Duty, Splash Proof, Sealed Motor, ignition Protected	24 VDC	10" x 5.0" x 4.75" [254 x 127 x 120mm]	4.0 GPM [15.1 LPM]	5	45 PSI [3.1 Bar]



BAIT SENTRY™ LIVEWELL PUMPS



The Bait Sentry™ Livewell Pumps are designed for easy installation and trouble-free operation. Magnetic Drive technology eliminates unnecessary failures. Motors keep running after ingesting debris or even when running dry. Patented anti-airlock feature allows the pump to clear trapped air in rough water or when boat is anchored. Includes dual port for easy washdown pump connection. **3 Year Warranty**

Name	Model # OEM/Aftermarket	Description	Tank Size (Gallons)	Dimensions	Port Size Inlet/Outlet	Flow Rate	Amps (Max.)
Bait Sentry™ 500 Magnetic Drive	1700-000-030 1700-001-030	12 VDC Continuous Duty, Ignition Protected, ISO 8846	30	4.93" x 7.85" [125 x 200mm]	3/4" Inlet NPT 3/4" Outlet BARB	500 GPH [1893 LPH]	1.75
Bait Sentry™ 800 Magnetic Drive	1700-010-030 1700-011-030		40	4.93" x 7.85" [125 x 200mm]	3/4" Inlet NPT 3/4" Outlet BARB	800 GPH [3028 LPH]	3.5
Bait Sentry™ 1100 Magnetic Drive (A)	1700-020-030 1700-021-030		60	4.93" x 7.85" [125 x 200mm]	3/4" Inlet NPT 1-1/8" Outlet BARB	1100 GPH [4164 LPH]	3.75

BILGE pumps

SHURFLO® 380 - 1000 GPH BILGE PUMPS

CE

Quality bilge pumps you can trust. SHURFLO bilge pumps are built for the harsh marine environment to withstand the toughest conditions. Standard with 3' Tinned Wire Assembly for below waterline installations. **3 Year Warranty**



Name	Model # OEM/Aftermarket	Description	Voltage	Dimensions	Round Footprint	Port Size Outlet	Flow Rate	Amps (Max.)
Bilge 380	355-020-00 355-020-10	Continuous Duty, Submersible with 3' Tinned Wire Assembly, Anti-Airlock, ABS Housing w/ Nylon Impeller, Ignition Protected, ISO 8849	12 VDC	4.2" x 3.75" [114 x 95mm]	2-3/8" [86mm]	3/4" [19mm]	380 GPH [1438 LPH]	1.7
Bilge 500	355-010-00 355-010-10		12 VDC	4.2" x 3.75" [114 x 95mm]	2-3/8" [86mm]	3/4" [19mm]	500 GPH [1893 LPH]	1.8
Bilge 700	355-110-00 355-110-10		12 VDC	4.2" x 3.75" [114 x 95mm]	2-3/8" [86mm]	3/4" [19mm]	700 GPH [2650 LPH]	3.2
Bilge 1000	355-100-00 355-100-10		12 VDC	4.2" x 3.75" [114 x 95mm]	2-3/8" [86mm]	1-1/8" [29mm]	1000 GPH [3785 LPH]	3.2

SHURFLO® 1500 - 2000 GPH BILGE PUMPS

CE

Heavy duty and built to last. SHURFLO's 1500 and 2000 GPH nylon bilge pumps offer a unique motor cooling system (patent pending) to ensure efficient performance and long life. Installation is a snap with our patented swivel base and 6' tinned wire assembly. **3 Year Warranty**



Name	Model # OEM/Aftermarket	Description	Voltage	Dimensions	Port Size Outlet	Flow Rate	Amps (Max.)
Bilge 1500	358-000-00 358-000-10	Continuous Duty, Submersible with 6' [1.8 m] Tinned Wire Assembly. Anti-Air lock, Swivel Baseplate, Ignition Protected, ISO 8849	12 VDC	7.2" x 6.0" [184 x 154mm]	1-1/8" Outlet Barb	1500 GPH [5677 LPH]	8
Bilge 2000	358-010-00 358-010-10		12 VDC	7.2" x 6.0" [184 x 154mm]	1-1/8" Outlet Barb	2000 GPH [7569 LPH]	10
Bilge 1500	358-100-00 358-100-10		24 VDC	7.2" x 6.0" [184 x 154mm]	1-1/8" Outlet Barb	1500 GPH [5677 LPH]	4
Bilge 2000	358-110-00 358-110-10		24 VDC	7.2" x 6.0" [184 x 154mm]	1-1/8" Outlet Barb	2000 GPH [7569 LPH]	5

SHURFLO® BILGE SWITCH

CE

The SHURFLO Series float switches provide the ultimate in reliability for your boat. Complete line includes a standard automatic float switch and a caged automatic float switch. **3 Year Warranty**



Name	Model # OEM/Aftermarket	Description	Voltage	Dimensions	Amps (Max.)
Standard Automatic Float Switch (A)	359-101-30 359-111-30	Non-Mercury, Remote or Direct Mounting 3' Tinned Wire, Assembly, Ignition Protected, ISO 8849	12/24 VDC	4.4" x 3.6" x 1.3" [112 x 92 x 32mm]	12
Caged Automatic Float Switch (B)	359-101-40 359-111-40	Non-Mercury, Remote or Direct Mounting 3' Tinned Wire, Assembly, Ignition Protected, ISO 8849	12/24 VDC	5.1" x 4.0" x 2.8" [130 x 102 x 71mm]	12

BLOWERS

in-line



YELLOWTAIL™ IN-LINE BLOWERS



A



B

SHURFLO has developed a unique nylon fan that includes 6 blades to ensure high performance and efficient ventilation. Installation of the Yellowtail™ Blower is made easy with extended barbs and slotted mounting bracket. **3 Year Warranty**

Name	Model # OEM/Aftermarket	Description	Dimensions	CFM	Amps (Max.)
3" YellowTail™ Blower (A)	277-3100 277-3110	12 VDC, CE, Continuous Duty, ISO 9097 Marine, Ignition Protected, USCG 183.410 Compliant, NMMA Type Accepted, ABYC	5.1" x 5.5" x 3.8" [130 x 140 x 96mm]	120	3.8
4" YellowTail™ Blower (B)	277-4100 277-4110	12 VDC, CE, Continuous Duty, ISO 9097 Marine, Ignition Protected, USCG 183.410 Compliant, NMMA Type Accepted, ABYC	5.1" x 6.4" x 4.8" [130 x 162 x 122mm]	220	5.5

MACERATOR

pumps



MACERATOR PUMPS



A

Designed specifically for sanitation waste and fish box evacuations, SHURFLO's Macerator pump features a premium impeller design with run-dry capability and includes our seamless shell motor with o-ring sealed end bells and a sealed manual turn key. SHURFLO's unique dual blade and housing construction ensures problem free pumping, providing superior performance in harsh marine environments. Thermally protected and ignition protected. **1 Year Warranty**

Name	Model # OEM/Aftermarket	Voltage	Dimensions	Flow Rate	Amps	Port Size
Macerator 12 VDC (A)	3200-000 3200-001	12 VDC	10.6" x 4.9" x 3.8" [269 x 125 x 97mm]	13 GPM [49 LPM]	17	Inlet 1-1/2" Barb/ 1-1/2" NPT Outlet 1" Barb
Macerator 12 VDC 180 Degree Port	3200-100 3200-101	12 VDC	10.6" x 4.9" x 3.8" [269 x 125 x 97mm]	13 GPM [49 LPM]	17	Inlet 1-1/2" Barb/ 1-1/2" NPT Outlet 1" Barb
Macerator 24 VDC	3200-010 3200-011	24 VDC	10.6" x 4.9" x 3.8" [269 x 125 x 97mm]	13 GPM [49 LPM]	9	Inlet 1-1/2" Barb/ 1-1/2" NPT Outlet 1" Barb
Macerator 24 VDC 180 Degree Port	3200-110	24 VDC	10.6" x 4.9" x 3.8" [269 x 125 x 97mm]	13 GPM [49 LPM]	9	Inlet 1-1/2" Barb/ 1-1/2" NPT Outlet 1" Barb

UTILITY

pumps

GENERAL PURPOSE PUMPS

CE

Incorporating SHURFLO's advanced motor technology that includes thermal overload protection, these pumps are self-priming, easy to install and are extremely versatile—perfect for a variety of uses including winterizing, oil changing and liquid transfer. **1 Year Warranty**

Name	Model # OEM/Aftermarket	Description	Dimensions	Flow Rate	Amps (Max.)	Port Size
Utility Pump Standard (A)	8050-305-526 8050-305-526	12 VDC - Ignition Protected. BUNA Valves, CE, 7' [2.1m] Prime, Hose kit Included, Uses: Winterizing, Oil Change and Liquid Transfers	6.5" x 4.5" x 4.3" [165 x 114 x 108mm]	1.5 GPM [5.6 LPM]	4	3/8" F NPT
Utility Pump Premium (B)	8050-305-626 8050-305-626	12 VDC - Ignition Protected. BUNA Valves, CE, 7' [2.1m] Prime, 8' Cable with Battery Clips, Hose kit Include, Uses: Winterizing, Oil Change and Liquid Transfers	7.8" x 4.5" x 4.3" [198 x 114 x 106mm]	1.5 GPM [5.6 LPM]	4	3/8" F NPT
Oil Change/Winterizing System (C)	8050-305-426 8050-305-426	12 VDC - 8' [2.4 m] Cable w/ Battery Clips, CE, Hose kit and 3.5 Gal [13L] Storage Container, Uses: Oil changing, winterizing and liquid transfer	16" H x 12.5" D [406 x 318mm]	1.5 GPM [5.6 LPM]	4	3/8" F NPT
Drill Pump (D)	3010-000 3010-000	1/4" [6mm] Drill Shaft - Flexible BUNA Impeller, 8' [2.4m] Prime, Uses: Oil Change and Liquid Transfers	—	200 GPH [757 LPH]	—	3/4" GSH M
Nautilus™ (E)	100-049-21	12 VDC - Single Fixture Water Delivery, Thermal Overload, Must have In-Line Switch & 3 Amp Fuse, Uses: Single Fixture Applications	4.8" x 2.6" x 1.9" [122 x 66 x 49mm]	1.0 GPH [4.0 LPH]	2.5	3/8" Barb [10mm]



SPECIALTY PUMPS

CE

Specifically designed for refrigeration cold plate circulation, each pump features a positive displacement three-chamber diaphragm and EPDM valves for proven priming ability and longer life. **1 Year Warranty**

Name	Model # OEM/Aftermarket	Description	Dimensions	Flow Rate	Amps (Max.)	Maximum Pressure
Refrigeration Circulation Pump (A)	8050-261-105 8050-261-105	12 VDC-CE Version, No switch, Continuous Duty Motor, Cold Plate Refrigeration Pump	7.3" x 4.3" x 4.4" [185 x 109 x 112mm]	0.5 GPM [1.9 LPM]	1.5	30 PSI [2.1 BAR]
Refrigeration Circulation Pump (B)	4728-110-E10 4728-110-E10	12 VDC-CE Version, No switch, Continuous Duty Motor, Cold plate Refrigeration Pump	7.2" x 4.9" x 4.5" [183 x 125 x 114mm]	1.5 GPM [5.7 LPM]	2.8	40 PSI [2.8 BAR]



CLOSED COUPLED CENTRIFUGAL PUMP

CE

SHURFLO close-coupled, 316 stainless steel, semi-open impeller centrifugal models pump continuously, producing high flow rates under low-head conditions. Designed for continuous low pressure circulation and transfer of nonflammable liquids, utility, boiler feed, general transfer, marine applications, water circulation, engine cooling where no suction lift or no self-priming is required.

Name	Model #	Voltage	Dimensions	Flow Rate	Amps (Max.)	Maximum Pressure
Centrifugal Pump	COMSV012D	12 VDC	7.2" x 4.0" x 4.0" [182 x 102 x 102mm]	21 GPM [79.4 LPM]	10.4	10 PSI [0.7 BAR]
Centrifugal Pump	COMSV024D	24 VDC	7.2" x 4.0" x 4.0" [182 x 102 x 102mm]	21 GPM [79.4 LPM]	7.8	10 PSI [0.7 BAR]



WATER system accessories

CE WATER SYSTEMS ACCESSORIES

Designed for safety and convenience, SHURFLO accessories are built to last. Big protection from small, yet essential products. **1 Year Warranty**



Name	Model # OEM/Aftermarket	Description	Port Size
Twist-On Water Strainer	255-223 255-323	Easy Assembly, Keeps Debris Out of Pump, Transparent, Easy to See when Strainer Needs Cleaning, 50 Mesh Stainless Steel Screen	1/2" [13mm] Barb Inlet
Twist-On Water Strainer (A)	255-213 255-313	Easy Assembly, Keeps Debris Out of Pump, Transparent, Easy to See when Strainer Needs Cleaning, 50 Mesh Stainless Steel Screen	1/2" [13mm] Pipe Inlet
Swivel Nut Water Strainer	255-215 255-315	Easy Assembly, Keeps Debris Out of Pump, Transparent, Easy to See when Strainer Needs Cleaning, 50 Mesh Stainless Steel Screen	1/2" [13mm] Pipe Inlet
Barb Inlet Strainer	255-222 255-322	Easy Assembly, Keeps Debris Out of Pump, Transparent, Easy to See when Strainer Needs Cleaning, 50 Mesh Stainless Steel Screen	1/2" [13mm] Barb Inlet
Swivel Nut Water Strainer (B)	255-225 255-325	Easy Assembly, Keeps Debris Out of Pump, Transparent, Easy to See when Strainer Needs Cleaning, 50 Mesh Stainless Steel Screen	1/2" [13mm] Barb Inlet
In-Line Check Valve (C)	340-000 340-001	Allows Flow in One Direction Only to Safeguard Against Backsurge up to 100 PSI [6.8 BAR]	1/2" Barb [13mm]
High Pressure Blaster Nozzle (D)	15-010 94-010-00	High Impact Plastic for Long Life, Use with SHURFLO Pumps or Garden Hose, Adjusts to Fine Mist or Full Stream, Lock Clip for Continuous Spray	3/4" Garden Hose thread
Self-Coiling Hose (E)	7-071-25	25', 3/8" Diameter, White Coiled Hose	3/4" Garden Hose Thread
Self-Coiling Hose (F)	7-137-25	25', 1/2" Diameter, Blue Coiled Hose	3/4" Garden Hose Thread

CE PRE-PRESSURIZED ACCUMULATOR TANKS

Reduce cycling pulsation and pressure spikes, increase the life of your pump—and even save battery power. Easily handles pressure requirements from 20 PSI to 125 PSI. **1 Year Warranty**



Name	Model # OEM/Aftermarket	Dimensions	Total Volume	Maximum PSI	Precharged
24 oz. Nylon Tank (A)	182-100 182-200	9.1" x 4.8" x 3.8" [232 x 121 x 97mm]	24 oz. [710 mL]	125 PSI [8.8 BAR]	30 PSI [2.0 BAR]
24 oz. Nylon Tank	182-102 182-202	9.1" x 4.8" x 3.8" [232 x 121 x 97mm]	24 oz. [710 mL]	125 PSI [8.8 BAR]	20 PSI [1.4 BAR]
2 Gallon Stainless Steel Tank (B)	3400-002 3400-002	12" H, 9" D [23cm H, 10cm D]	2 Gallons [8.0 L]	100 PSI [7.03 BAR]	20 PSI [1.4 BAR]

PRESSURE REDUCING CITY WATER ENTRIES

CE

SHURFLO's exclusive diaphragm design prevents high-pressure damage often caused by city water systems. These high performance water entries limit water pressure and they include a check valve. 3/4" GSH Female swivel inlet. 1/2" NPSM - Male Outlet.

Name	Model #		Color
	OEM/Aftermarket	OEM/Aftermarket	
50 PSI Model		65 PSI Model	
Wall Mount (A)	183-020-04 183-029-04	183-020-14 183-029-14	Chrome
Wall Mount (B)	183-020-08 183-029-08	183-020-18 183-029-18	Gel White
In-Line (C)	183-039-01	N/A	Cream
In-Line	183-039-08	N/A	Gel White

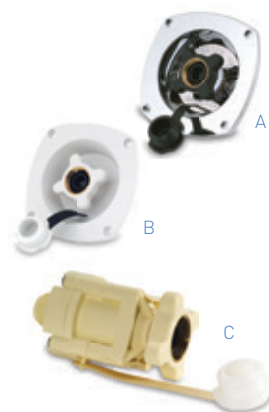

FILTRATION

IN-LINE WATER FILTERS

WATERguard
FILTRATION

CE

Model # / Name	Cartridge Media	Description	Taste & Chlorine	Heavy Metals	THM's VOC's	Pesti-cides	Micro Rating	Fittings/Port Size and Accessories
RV-210GH-A City Water Entry In-Line Filter (A)	Activated Carbon	Long life, triple-stage Carbon in-line city water entry filter with garden hose ends	●		●	●	5	3/4" Garden Hose Ports
RV-210GH-KDF-A City Water Entry In-Line Filter	KDF /Carbon	Long life, high quality quad-stage bacteriostatic KDF/carbon in-line city water entry filter with garden hose ends	●	●	●	●	5	3/4" Garden Hose Ports
RV-210BRB-A 11" City Water Entry In-Line Filter	Activated Carbon	Long life, triple-stage Carbon in-line city water entry filter with 1/2" Barb fittings	●		●	●	5	1/2" Barb Ports
94-009-50 10" In-Line Interior Filter (B)	KDF /Carbon	Long-life, high quality quad-stage bacteriostatic KDF/carbon in-line filter with fittings for every interior need	●	●	●	●	5	1/4" NPT-F Both Ends, fittings included: 2 ea. 1/2" MPT, 2 ea. Quick Connect & 2 ea. ColderFittings



EVERPURE® FILTERS

EVERPURE

CE

Model # / Name	Cartridge Media	Description	Taste & Chlorine	Heavy Metals	Cyst	THM's VOC's	Pesti-cides	Micro Rating
EV959206 Everpure® Full-Timer (A)	Micro-Pure Pleated	Exclusive technology reduces 99.9% of all particles 1/2 micron in size	●		●	●		0.5
EV959207 Everpure® Part-Timer (B)	Carbon Block	Exclusive technology reduces 99.9% of all particles 1/2 micron in size, Twin-pack	●		●	●		0.5



COMPLETE AFTERMARKET FILTER SYSTEM COMPONENTS

CE

Model #	Name	Includes	Description
EV925205	Everpure® Complete Kit	EV925206 Filter, Housing, By-Pass, Installation Kit	Exclusive Everpure filtration system, includes installation kit and super chlorination disinfection kit. Protects against bacteria, viruses and cysts down to 1/2 micron in size



PUMP fittings

CE STRAIGHT FITTINGS



A

Model # Straight Fittings	Style	Material	Description
244-2916	Wingnut Swivel	Nylon	1/2"-15 NPT (F) x 3/8" Barb
244-2926 (A)	Wingnut Swivel	Nylon	1/2"-14 NPT (F) x 1/2" Barb
244-2936	Wingnut Swivel	Nylon	1/2"-14 NPT (F) x 5/8" Barb
244-2946	Wingnut Swivel	Nylon	1/2"-14 NPT (F) x 3/4" Barb
244-5146	Adapter	Nylon	1/2" NPT (M) x 3/4" Barb

CE ELBOW FITTINGS



A

Model # Elbow Fittings	Style	Material	Description
244-3366	Wingnut Swivel	Nylon	1/2"-14 NPT (F) x 1/2"-14 NPT (M)
244-3916	Wingnut Swivel	Nylon	1/2"-14 NPT (F) x 3/8" Barb
244-3926 (A)	Wingnut Swivel	Nylon	1/2"-14 NPT (F) x 1/2" Barb
244-3936	Wingnut Swivel	Nylon	1/2"-14 NPT (F) x 5/8" Barb
244-3946	Wingnut Swivel	Nylon	1/2"-14 NPT (F) x 3/4" Barb

CE GARDEN HOSE WINGNUT FITTING



Model # Wing Nut Fitting	Style	Material	Description
244-2356	Wingnut Swivel	Nylon	3/4" GHT (M) x 1/2" NPT (F)

CE SWIVEL STRAIGHT FITTING ADAPTER



Model # Fitting Adapter	Style	Material	Description
244-2866	Wingnut Swivel (Pump/Accumulator Fitting)	Nylon	1/2" NPT (F) x 1/2" NPT (F)

CE TEE FITTING



Model # Tee Fitting	Style	Material	Description
244-4522	Barb Tee	Polypropolene	1/2" Barb x 1/2" Barb x 1/2" Barb

PUMP REPAIR & rebuild kits

SHURFLO pumps have set the standard for marine performance and reliability. To keep that performance and reliability at its peak, SHURFLO offers a wide range of kits for bench and field repair of its products. For detailed listings of individual part numbers, refer to SHURFLO pricing guides and repair manuals. This overview indicates the type of kits available.

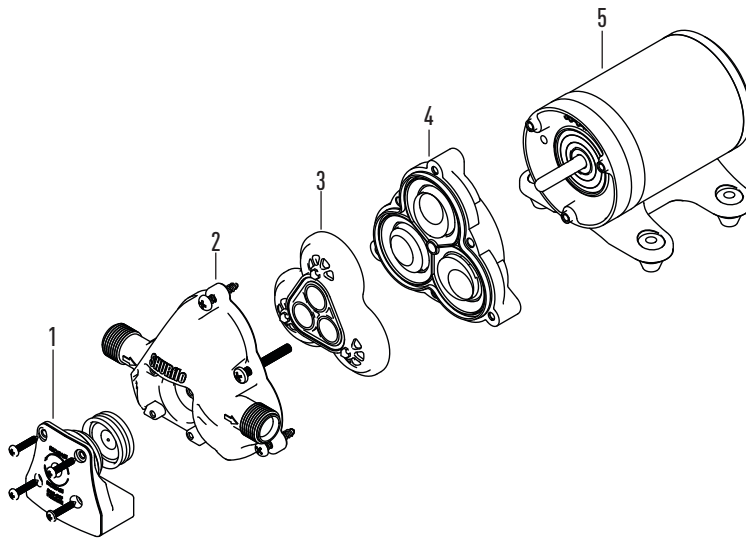

2901 / 3901 SERIES

Name	Model # OEM/Aftermarket	Switch	Upper Housing	Valve Assembly	Drive Assembly
		1	2	3	4
Aqua King™ Standard 12 V 30 PSI (2.1 bar)	3901-0203 3901-0213	94-706-04	94-706-01	94-706-02	94-706-06
Aqua King™ Standard 24 V 30 PSI (2.1 bar)	3901-1203 3901-1213	94-706-04	94-706-01	94-706-02	94-706-06
Aqua King™ Standard 12 V 45 PSI (3.1 bar)	3901-0204 3901-0214	94-706-03	94-706-01	94-706-02	94-706-06
Aqua King™ Standard 24 V 45 PSI (3.1 bar)	3901-1204 3901-1214	94-706-03	94-706-01	94-706-02	94-706-06
Blaster™ 12 V 45 PSI (3.1 bar)	3901-2204 3901-2214	94-706-03	94-706-01	94-706-02	94-706-06
Blaster™ 24 V 45 PSI (3.1 bar)	3901-3204 3901-3214	94-706-03	94-706-01	94-706-02	94-706-06
Pro Blaster™ Junior 30 PSI (2.1 bar)	2901-6203 2901-6213	94-706-04	94-706-01	94-706-02	94-706-06
Aqua King™ Junior 12 V 30 PSI (2.1 bar)	2901-0203 2901-0213	94-706-04	94-706-01	94-706-02	94-706-06
Aqua King™ Junior 12 V 20 PSI (1.4 bar)	2901-0202 2901-0212	94-706-05	94-706-01	94-706-02	94-706-06

PUMP REPAIR

4129 / 4139 SERIES

Name	Model # OEM/Aftermarket	Upper Assembly	Valve Assembly	Drive Assembly	Motor & Gasket	Pump Head	Check Valve (Not Shown)
		1	2	3	4	5	6
AQUA KING™ II Junior 2.0	4129-110-A02 4129-110-B02	94-800-41	94-800-01	94-800-25	94-71-003-07	94-800-32	94-800-03
AQUA KING™ II Standard 3.0	4139-111-A54 4139-111-B54	94-800-42	94-800-01	94-800-26	94-71-005-07	94-800-33	94-800-03
AQUA KING™ II Standard 3.0	4139-111-A87 4139-111-B87	94-800-43	94-800-01	94-800-26	94-71-005-07	94-800-34	94-800-03
AQUA KING™ II Standard 3.0	4139-131-B54	94-800-42	94-800-01	94-800-26	94-71-006-07	94-800-33	94-800-03
AQUA KING™ II Standard 3.0	4139-131-A87 4139-131-B87	94-800-43	94-800-01	94-800-26	94-71-006-07	94-800-34	94-800-03

4129 / 4139 SERIES

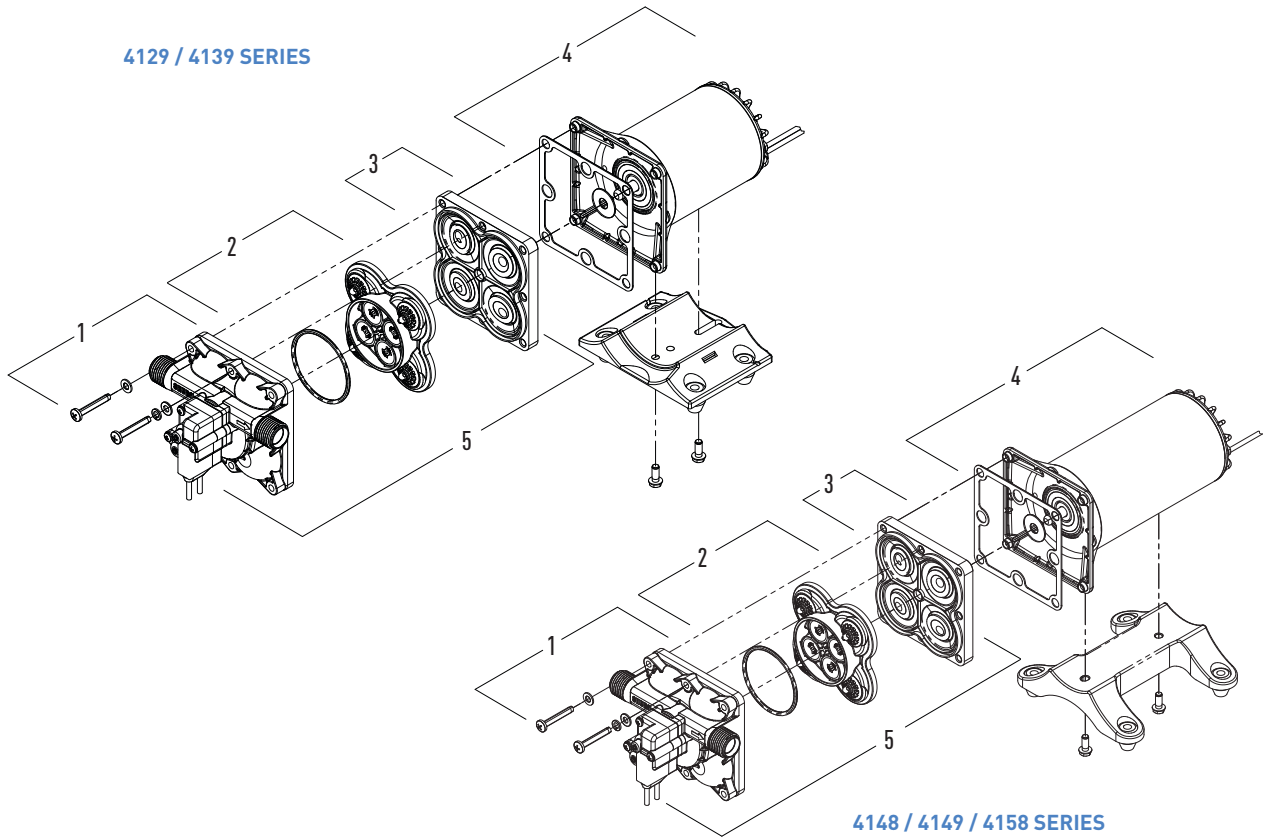

4148 / 4149 / 4158 SERIES

4148 / 4149 / 4158 SERIES

Name	Model # OEM/Aftermarket	Upper Assembly	Valve Assembly	Drive Assembly	Motor & Gasket	Pump Head	Check Valve (Not Shown)
		1	2	3	4	5	6
AQUA KING™ II Premium 4.0	4148-153-A75 4148-153-E75	94-801-10	94-800-01	94-801-02	94-71-001-07	94-801-11	94-800-03
AQUA KING™ II Premium 4.0 24 V	4148-163-A75 4148-163-E75	94-801-10	94-800-01	94-801-02	94-71-001-03	94-801-11	94-800-03
AQUA KING™ II Premium 4.0	4149-153-A86 4149-153-B86	94-801-16	94-800-01	94-801-02	94-71-001-07	94-801-17	94-800-03
AQUA KING™ II Supreme 5.0	4158-153-A75 4158-153-E75	94-801-10	94-800-01	94-801-02	94-71-004-17	94-801-11	94-800-03
AQUA KING™ II Supreme 5.0 24 V	4158-163-A75 4158-163-E75	94-801-10	94-800-01	94-801-12	94-71-001-04	94-801-13	94-800-03

& rebuild kits

4238 SERIES

Name	Model # OEM/Aftermarket	Upper Assembly	Valve Assembly	Drive Assembly	Motor & Gasket	Pump Head	Check Valve (Not Shown)
BLASTER™ II	4238-121-A07 4238-121-E07	1	2	3	4	5	6
BLASTER™ II 24 VDC	4238-141-A07 4238-141-E07	94-800-13	94-800-01	94-800-15	94-71-002-07	94-800-17	94-800-03

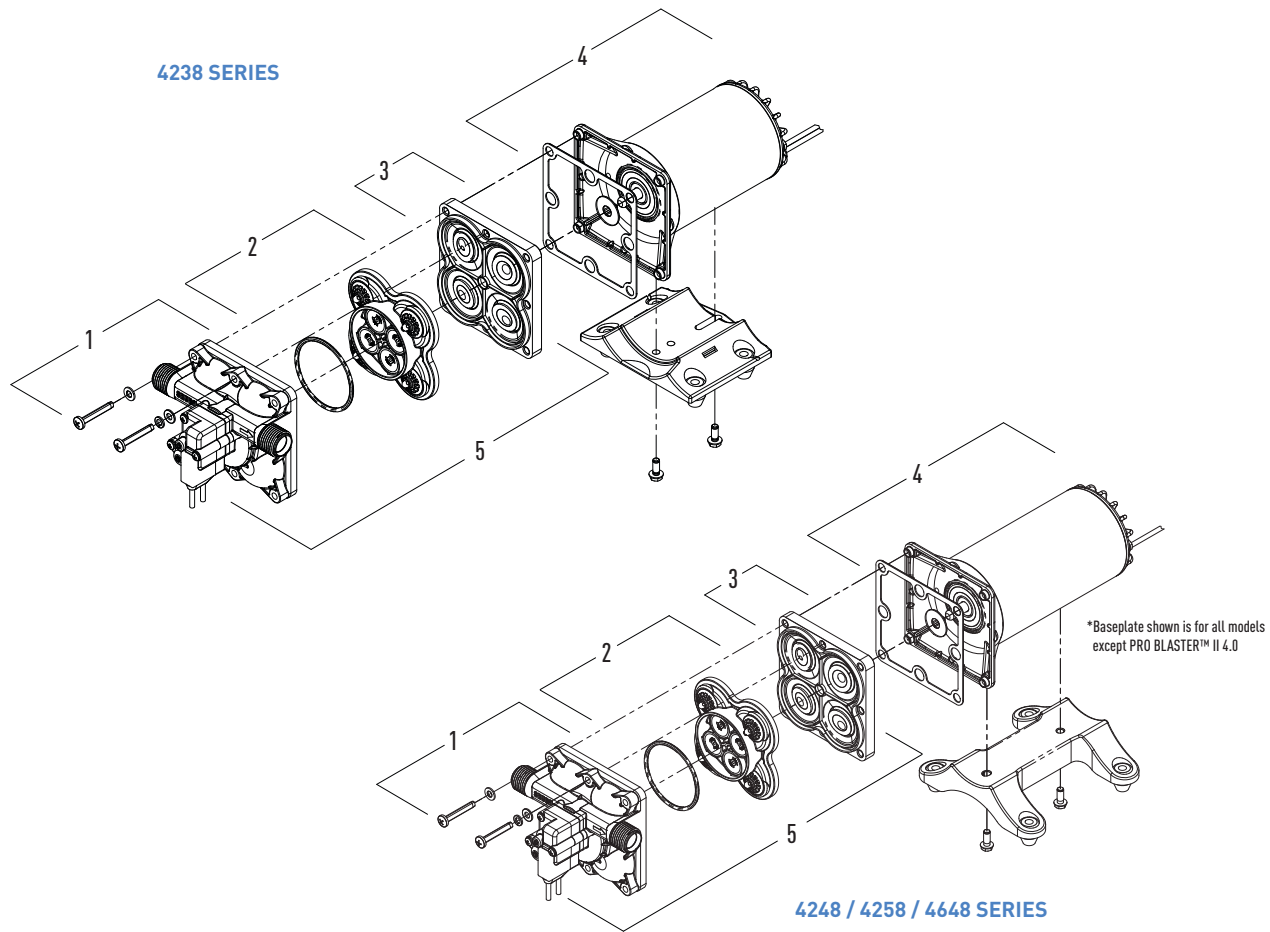

4248 / 4258 / 4648 SERIES

Name	Model # OEM/Aftermarket	Upper Assembly	Valve Assembly	Drive Assembly	Motor & Gasket	Pump Head	Check Valve (Not Shown)
PRO BLASTER™ II Deluxe 4.0	4248-153-A09 4248-153-E09	1	2	3	4	5	6
PRO BLASTER™ II Deluxe 4.0 24 VDC	4248-163-A09 4248-163-E09	94-804-02	94-800-01	94-801-02	94-71-001-03	94-804-03	94-800-03
PRO BLASTER™ II Ultimate 5.0	4258-153-A09 4258-153-E09	94-804-02	94-800-01	94-801-02	94-71-004-17	94-804-03	94-800-03
PRO BLASTER™ II Ultimate 5.0 24 VDC	4258-163-A09 4258-163-E09	94-804-02	94-800-01	94-801-02	94-71-001-04	94-804-03	94-800-03
PRO BAITMASTER™ II 4.0	4648-153-A07 4648-153-E07	94-805-01	94-800-01	94-801-02	94-71-001-07	94-805-02	94-800-03
PRO BAITMASTER™ II 4.0 24 VDC	4648-163-A07 4648-163-E07	94-805-01	94-800-01	94-801-02	94-71-001-03	94-805-02	94-800-03

PUMP REPAIR

4901 SERIES

Name	Model # OEM/Aftermarket	Switch	Upper Housing	Valve Assembly	Drive Assembly
		1	2	3	4
Aqua King™ Premium 45 PSI (3.1 bar)	4901-4202 4901-4212	94-668-00	94-670-01	94-669-00	94-670-00
Aqua King™ Premium 30 PSI (2.1 bar)	4901-4205 4901-4215	94-668-01	94-670-01	94-669-00	94-670-00
Pro Blaster™	4901-4292 4901-4282	94-668-00	94-670-01	94-669-00	94-670-00
Pro Blaster™ 24 VDC	4901-5292 4901-5282	94-668-00	94-670-01	94-669-00	94-670-00
Smart Sensor™ 4.0 12 VDC	4901-0201 4901-0211	—	94-670-01	94-669-00	94-670-00
Smart Sensor™ 4.0 24 VDC	4901-1201 4901-1211	—	94-670-01	94-669-00	94-670-00

4901 SERIES

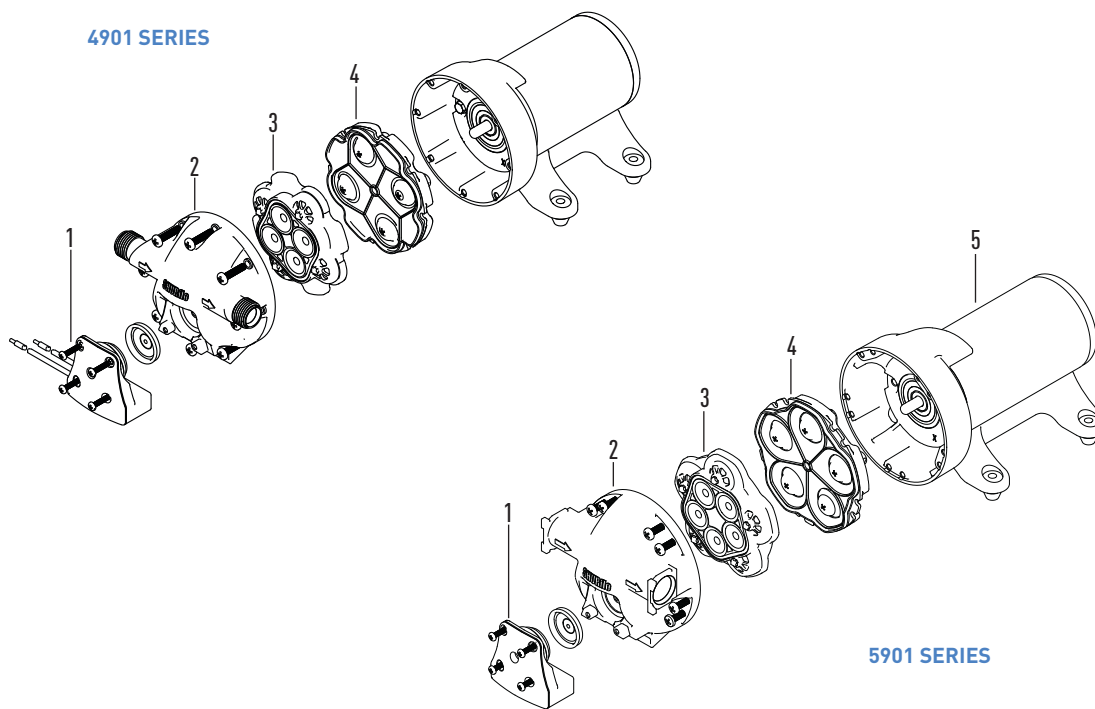

5901 SERIES

Name	Model # OEM/Aftermarket	Switch	Upper Housing	Valve Assembly	Drive Assembly**	Motor
		1	2	3	4	5
Smart Sensor™ 5.7 12 VDC	5901-0201 5901-0211	—	94-670-02	94-030-01	94-030-02	—
Smart Sensor™ 5.7 24/32 VDC	5901-1201 5901-1211	—	94-670-02	94-030-01	94-030-02	—
Extreme™ ProBlaster™ 12 VDC	5901-2202 5901-2212	94-069-00	94-670-02	94-030-01	94-030-02	94-77-007-17
Extreme™ ProBlaster™ 24 VDC	5901-3202 5901-3212	94-069-00	94-670-02	94-030-01	94-030-02	94-77-009-17
Extreme™ ProBlaster™ 32 VDC	5901-4202 5901-4212	94-069-00	94-670-02	94-030-01	94-030-02	94-77-010-17

** For use on pumps manufactured June 2006 or later.

& rebuild kits

8050 SERIES

Name	Model # OEM/Aftermarket	Pumphead Repair Kit	Switch	Check Valve	Upper Housing	Valve Assembly	Drive Assembly
Utility Pumps	8050-305-XXX 8050-305-XXX	1	2	3	4	5	6
		—	—	—	—	94-391-12	94-385-42

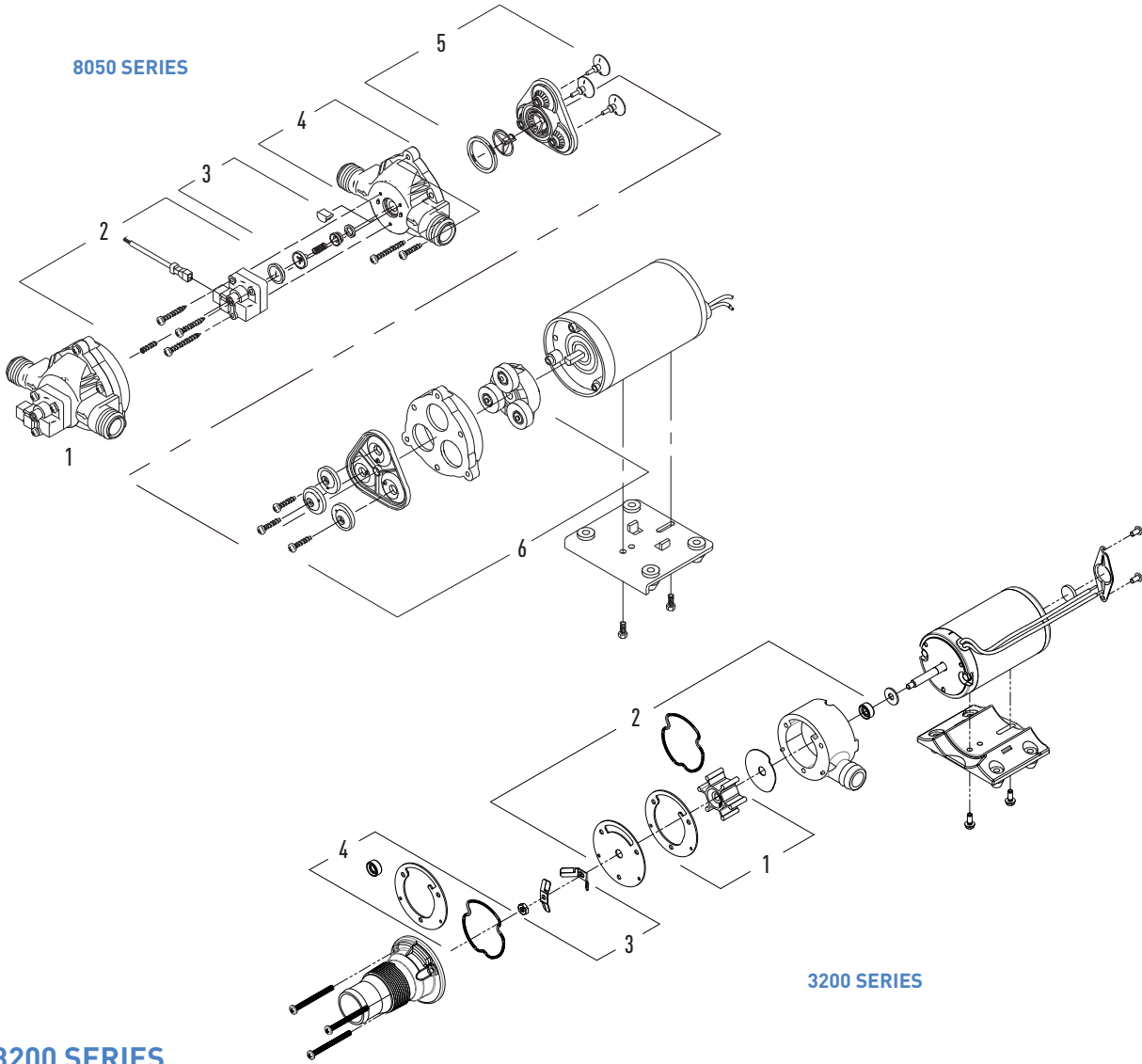

3200 SERIES

Name	Model # OEM/Aftermarket	Impeller Kit	Impeller Housing Kit	Blade Kit	Lip Seal Kit
Macerator 12 VDC	3200-000 3200-001	1	2	3	4
Macerator 12 VDC 180 Degree Port	3200-100 3200-101	94-571-00	94-570-00	94-570-02	94-570-04
Macerator 24 VDC	3200-010 3200-011	94-571-00	94-570-00	94-570-02	94-570-04
Macerator 24 VDC 180 Degree Port	3200-110 3200-111	94-571-00	94-570-00	94-570-02	94-570-04

INSTALLATION guidelines

BILGE PUMPS

Recommended mounting: attach base to hull or stringer using stainless steel screws. Snap pump into base.

CAUTION: Care must be taken not to drive the screws through the hull. Be sure pump is mounted on a flat surface, as low as possible in the bilge.

Attach 3/4" [19mm] (380, 500 & 700 GPH) or 1-1/8" [29mm] (1000 GPH) I.D. smooth bore hose. Use of a smooth bore hose will ensure maximum pump performance. Corrugated hose will significantly reduce pump performance. Route discharge hose to a thru-hull fitting well above the water line. Avoid any sagging or loops in the hose. Vertical lift over 3' [2.1m] significantly reduces output performance. Be sure to check clamp tightness at pump and thru-hull fittings.

CAUTION: Do not use open flame in the bilge area. Refer to Full Line Application and Specification Chart for individual pump recommended wire and fuse sizes.

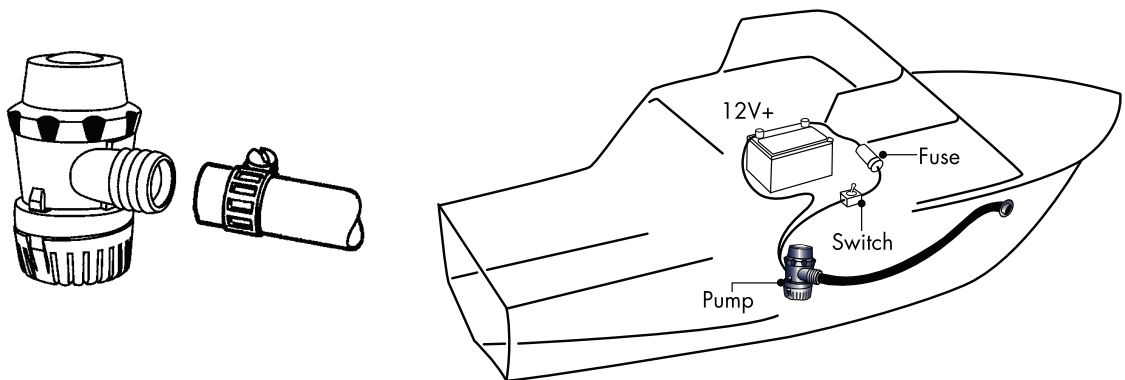

FRESH WATER MULTI-FIXTURE SYSTEMS

The pump may be mounted up to six vertical feet above the source. Wiring should be switched as well as fused with the recommended size fuse. The inlet side of all fresh water pumps should include the use of a SHURFLO strainer. Mount the pump in an accessible area for strainer inspection. Refer to Application and Specification Chart for individual pump recommended wire and fuse sizes.

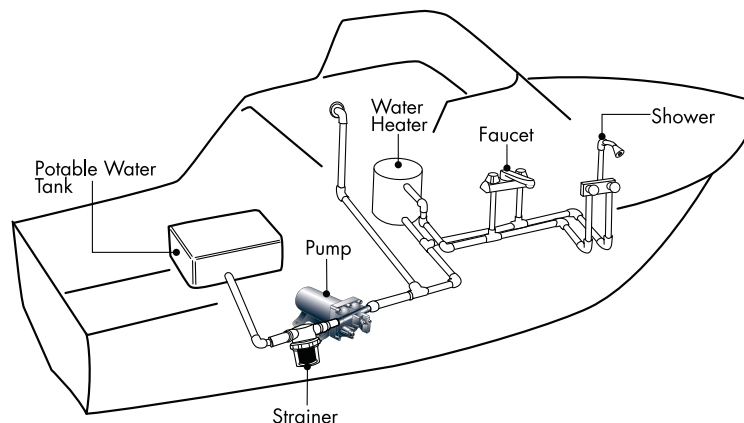

LIVEWELL PUMPS

For livewell systems, SHURFLO recommends marine approved reinforced hose. Always use double stainless steel clamps for plumbing below the water line. A sea-cock valve must be installed between the pump and the thru-hull fitting. Pump impeller must be below the water line. To prevent an airlock situation, do not allow outlet tubing to sag between pump and tank. Discharge port on pump must be pointed up toward tank, not down towards keel.

When plumbing the livewell pump to a washdown pump, use a Raw Water Strainer between the livewell pump and the washdown pump. Tubing should be no smaller than 1/2" [13mm] marine approved reinforced tubing. Refer to the SHURFLO installation manual for complete guidelines.

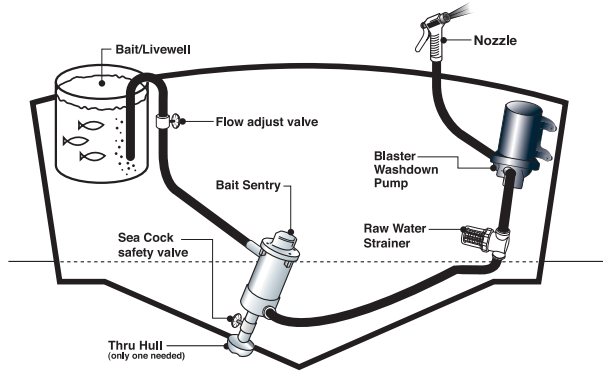

THE PRO BAITMASTER™ / PRO BAITMASTER™ II LIVEWELL PUMP

For livewell systems using the PRO BAITMASTER™/PRO BAITMASTER™ II, SHURFLO recommends marine approved reinforced hose. Use 1/2" [13mm] I.D. hose on tank inlet and outlet for minimum back pressure and turbulence to the live bait. A SHURFLO Raw Water Strainer between the thru-hull fitting and the pump inlet must be used.

Due to its marine tough SHURCote™ protection, the PRO BAITMASTER™/PRO BAITMASTER™ II can be mounted without regard to splashed water. Refer to the Full Line Application and Specification Chart for individual pump recommended wire fuse sizes.

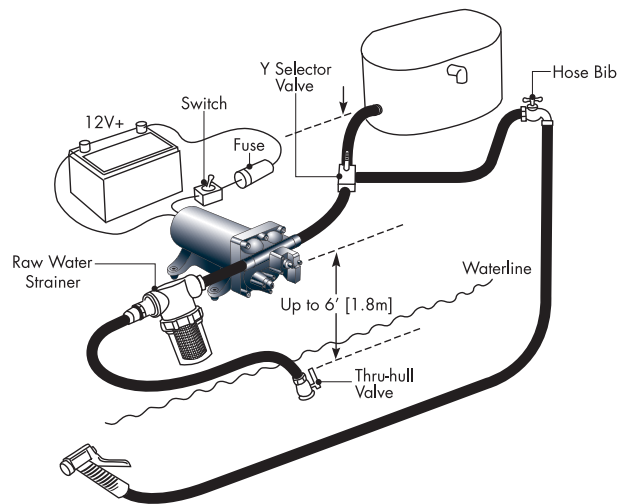

WASHDOWN SYSTEMS

For washdown systems using the BLASTER™/ BLASTER™ II/ PRO BLASTER™/PRO BLASTER™ II, SHURFLO recommends marine approved reinforced hose. For optimum performance, an inlet SHURFLO Raw Water Strainer is required. Use of the supplied hose nozzle will insure high pressure delivery. Refer to the Full Line Application and Specification Chart for individual pump recommended wire and fuse sizes.

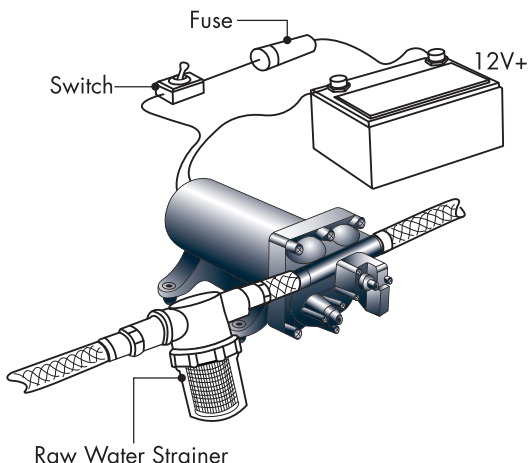

SHOWER SUMP SYSTEMS

The standard 3901/4138 model can be used for shower sump applications. The sump tray should employ a 6"- 8" trap with adequate strainer capability. Use a SHURFLO Raw Water Strainer on the inlet side of the pump, mounted in an easy access location for inspection.

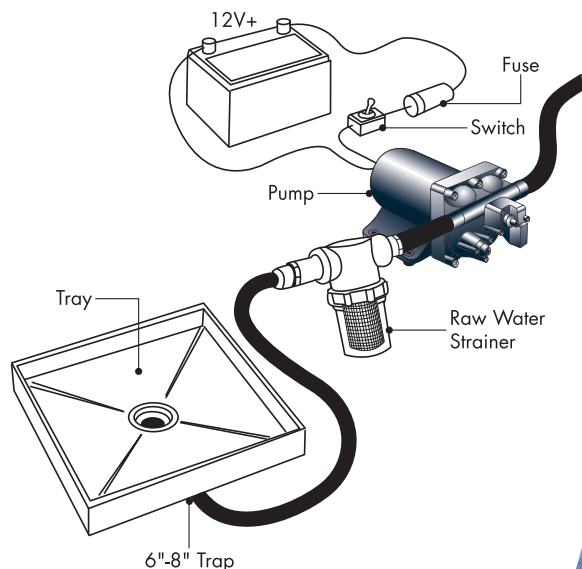

INSTALLATION guidelines

This brief installation guide for SHURFLO pump systems will answer the most often encountered questions about basic marine plumbing systems. Additional more detailed information is available through technical data sheets from SHURFLO, as well as the installation instruction sheets provided with each product.

For more information, contact your SHURFLO representative or SHURFLO customer service.

GENERAL NOTES

- All SHURFLO marine water pumps are ignition protected.††
- In order to minimize heat rise, continuously operating pumps other than bilge pumps should be mounted in well ventilated spaces.
- SHURFLO diaphragm pumps will operate in any position; however, the recommended position is motor up/pumphead down to prevent any possible water damage to the motor in the event of a leak during setup or operation. Mount on a solid surface to reduce noise and vibration.
- SHURFLO offers a variety of barbed and threaded fittings in straights and elbows from sizes 3/8" to 3/4".
- All SHURFLO 2093, 2095, 3901, 4901, 5901 & 4XXX threaded pump ports are internally tapered, to be thoroughly hand-tightened only with SHURFLO swivel fittings. They eliminate expensive brass or stainless fittings which require more complex plumbing.
- A safety sea-cock (thru-hull valve) is required for any installation using a thru-hull water source.
- In accordance with American Boat and Yacht Council (ABYC) guidelines, the recommended placement for all diaphragm pumps plumbed to a thru-hull fitting is above the waterline.
- The self-priming feature of SHURFLO diaphragm pumps allows them to be mounted any distance up to 30 feet [9.2m] horizontal from on-board water supplies, insuring easy access to plumbing connections and strainers, maximizing reduction of noise or vibration and minimizing exposure to splashed water.
- All SHURFLO pumps are engineered with rubber mounting feet to minimize noise and vibration and will function properly only if proper fasteners are used to snug down (not flatten) the feet. Flexible inlet and outlet plumbing (such as reinforced hose), is critical to lower pump noise level and increase pump life.
- SHURFLO recommends that all pumps be fused individually, in addition to any other circuit protection used such as circuit breakers.
- WATERguard™ and EVERPURE® filters are great for Marine applications. The filter may be installed in any convenient location. Be sure to keep the filter away from any heat source. All filters should be replaced seasonally (6-12 months) or when taste and odor problems return.

WIRE SIZE REQUIREMENTS

[Based on 10 Amps; 10% voltage drop]

Battery-to-pump distance	AWG [mm ²]
0-25 feet [0-7.6m]	16 [1.3]
25-50 feet [7.6-15.2m]	14 [2.1]
50-70 feet [15.2-21.3m]	12 [3.3]
70-110 feet [21.3-33.5m]	10 [5.3]

Minimum wire size for a 10% voltage drop on a 12VDC, 10 Amp Circuit. Length is the distance from the power source to pump and back to ground.

†[1/2"-14 National American Straight Pipe Thread]
††[Except 8050-305-626 & 8050-305-426]

PLUMBING GUIDELINES

[for long life and low noise]

SHURFLO Fittings	Hand tighten only.
Feet	Snug, don't flatten; solid surface
Pump/Hose	Flexible hose on inlet and outlet side of pump. 1/2" minimum on mains, 3/8" minimum on branch.
Water Purifier	Run Separate line from mains. 1/4" minimum recommended.
Noise Reduction	Use flexible hose. Check for air in system, including all drain lines and hot water heater lines.