

VOLVO PENTA AQUAMATIC

D3-130, 160, 190/SX

96–120–140 kW (130–163–190 hp) crankshaft power acc. to ISO 8665

Power for fun

Volvo Penta's 5-cylinder D3 is developed from the latest design in modern diesel technology. The engine is very lightweight and compact. With features like common rail fuel injection system, double overhead camshafts, 4 valves per cylinder, variable geometry turbocharger, aftercooler and the EVC (Electronic Vessel Control) a world-class diesel performance, combined with low emissions, is achieved.



World-class performance

The common rail fuel injection system, electronically controlled, in combination with the large swept volume and Variable Geometry Turbine (VGT), ensures outstanding torque during acceleration, with virtually no sign of smoke. This matched with the engine's low weight creates a real performer for boating fun.

Low weight

The engine has an extremely low weight for its power output. This thanks to the all aluminum base engine, and a highly efficient marinization. This contributes to a power/weight ratio comparable with a gasoline engine.

The engine is fitted with freshwater cooling as standard for long service life.

Compact and robust

The engine is ultra-compact for its large swept volume. With cast-in grey iron cylinder liners, integrated freshwater pump, a compact marinization, and a fully symmetric engine, the package simply gets that compact.

The rigid aluminum cylinder block and bed plate in wedge structure, and exactly controlled high-pressure fuel injection gives excellent onboard comfort with low noise and vibration levels.

EVC/MC - Plug and go

EVC Electronic Vessel Control is the latest development in instrumentation for marine engines with mechanical shift and throttle.

With EVC/MC you can tailor the instrumentation to fit the boat, from a single EVC system tachometer, where you can read all engine/boat data, to a dashboard full with standard gauges and an EVC system display, or any combination in between. EVC/MC offers new software functions such as trip computer and power trim assistant that will make boating both safer and easier (option).

The system is built on the latest automotive technology with waterproof connectors, so it's just plug and go. EVC works closely together with the engine management system offering you constant power output regardless of temperature (5–55°C/41–131°F) and quality of the fuel.

SX drive

The SX single propeller drive is a well-proven design with exhaust through the propeller hub and cavitation plate for quiet and efficient operation. Cone clutch for easy and smooth shifting. Pattern-matched spiral bevel gears for optimum strength and minimum gear whine. Break-away shaft coupling to prevent costly drive-train repairs.

The package is equipped with Power steering as standard for maximum driving comfort.

Meeting new emission standards

The common rail injection system in combination with electronics and an advanced combustion system are setting new standards in minimizing noxious emissions and particulates. The engine complies with IMO NOx limits (D3-190) and the comprehensive emission requirements EU RCD and US EPA Tier 2.

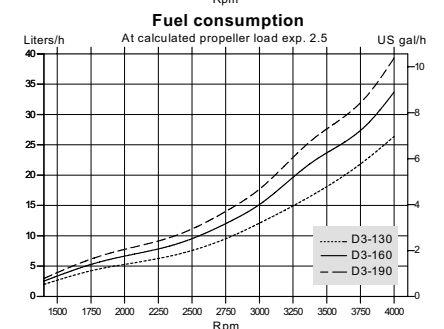
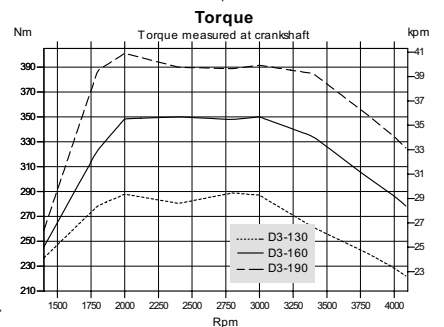
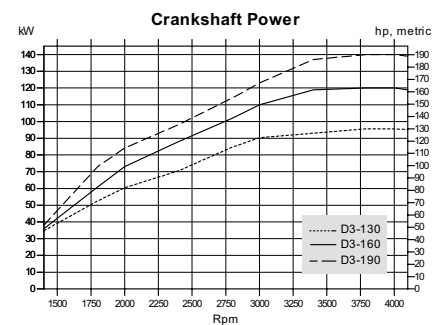

**VOLVO
PENTA**

D3-130,160,190/SX

Technical description:

Engine block and head

- Cylinder block and cylinder head made of aluminum
- Cylinder block with integrated bed plate
- 4-valve technology with hydraulic lash adjusters
- Double overhead camshafts
- Oil-cooled pistons with two compression rings and one oil scraper ring
- Cast-in grey iron cylinder liners
- Replaceable valve seats
- Six-bearing crankshaft
- Front-end transmission

Engine mounting

- Flexible engine mounting

Lubrication system

- Easily replaceable (insert) full-flow oil filter
- Plate oil cooler

Fuel system

- Common rail fuel injection system
- Control unit for processing the injection
- Fine filter with water separator

Air inlet and exhaust system

- Air filter with replaceable insert
- Closed crankcase ventilation with oil separator of cyclone type
- Stainless steel exhaust elbow

- Turbocharger with variable geometry

Cooling system

- Thermostatically regulated freshwater cooling
- Tubular heat exchanger with separate large volume expansion tank
- Coolant system prepared for hot water outlet
- Easily accessible impeller pump
- Integrated seawater coolant pick-up through drive
- Seawater strainer

Electrical system

- 12V one-pole electrical system
- 140A alternator, and integrated temperature compensated charging regulator
- Auxiliary stop button

Instruments/control (options)

- Mechanical shift and throttle
- Full range of instrumentation including key switch and interlocked alarm
- Digital Power Trim instrument with analog or digital reading
- Plug-in connectors

Drive

- Single propeller drive which can be run with both right- or left-hand propellers
- Cone clutch
- Pattern-matched spiral bevel gears

- Complete connection for exhaust outlet through propeller hub and cavitation plate
- Overload protection sleeve (break-away coupling)
- Max tilt angle 52°
- The drive can be turned 28° in each direction
- Built-in kick-up function to reduce possible damage, in the event the drive strikes an underwater object
- Active corrosion protection as accessory
- Integrated speedometer (pitot tube) pickup in lower drive leg
- Easy to access drive anode placed on the back of the cavitation plate

Power Trim

- Shield integrated high capacity trim pump for quick trim response and easy installation
- Instrument for indication of trim angle

Accessories

An extensive range of accessories are available. For detailed information, please see the Accessories & Maintenance Parts catalog (www.volvopenta.com).

Contact your local Volvo Penta dealer for further information.

Not all models, standard equipment and accessories are available in all countries. All specifications are subject to change without notice.

The engine illustrated may not be entirely identical to production standard engines.

Technical Data

Engine designation	D3-130 A	D3-160 A	D3-190 A
Crankshaft power, kW (hp)	96 (130)	120 (163)	140 (190)
Propeller shaft power, kW (hp)	90 (122)	114 (155)	133 (181)
Engine speed, rpm	4000	4000	4000
Displacement, l (in ³)	2.4 (146)	2.4 (146)	2.4 (146)
Number of cylinders	5	5	5
Bore/stroke, mm (in.)	81/93.2 (3.19/3.67)	81/93.2 (3.19/3.67)	81/93.2 (3.19/3.67)
Compression ratio	17.3:1	17.3:1	17.3:1
Volvo Penta Aquamatic drive	SX	SX	SX
Ratio	1.66:1	1.66:1	1.51:1
Dry weight with SX, excl. prop., kg (lb)	325 (716)	325 (716)	325 (716)

Duty rating: R5

Technical data according to ISO 8665. With fuel having an LHV of 42,700 kJ/kg and density of 840 g/liter at 15°C (60°F).

Merchant fuel may differ from this specification which will influence engine power output and fuel consumption.

The engine complies with IMO NOx (D3-190) and the comprehensive emission requirements EU RCD and US EPA Tier 2.

Dimensions D3-130,160,190/SX

Not for installation

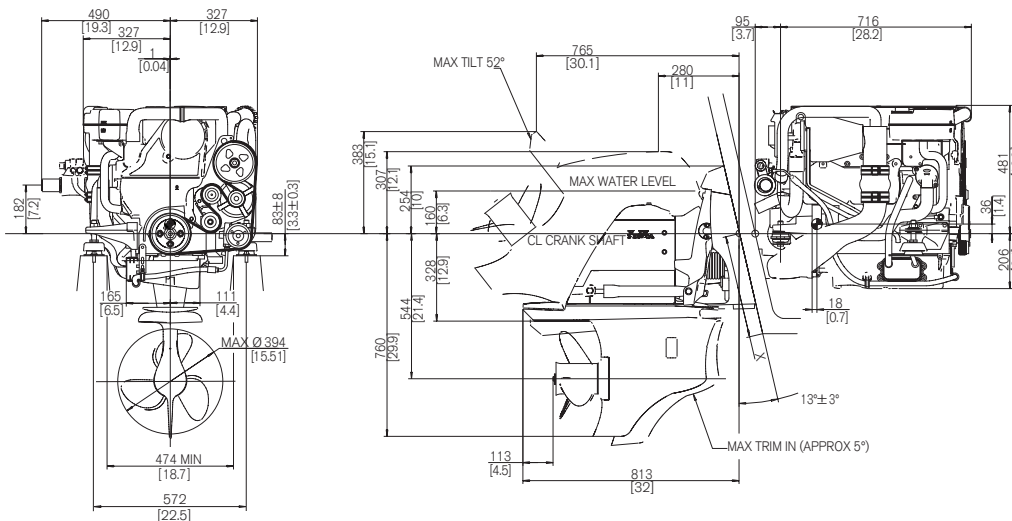

VOLVO PENTA

AB Volvo Penta
SE-405 08 Göteborg, Sweden
www.volvopenta.com